



INSTALLATION INSTRUCTIONS

Accessory
REMOTE CONTROL ENGINE STARTER

Application
2013 CR-V

Publications No.
All 13148
Issue Date
AUG 2012

PARTS LIST

Remote Control Engine Starter Unit Kit P/N 08E91-E22-101A

Transmitter

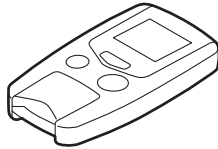

Control unit

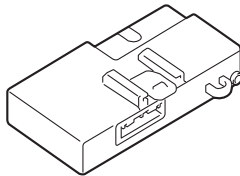

Antenna

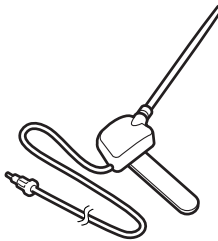

Key ring



Protective tape



Fuse label

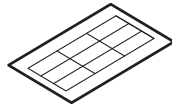

Caution label



Accessory User's Information Manual

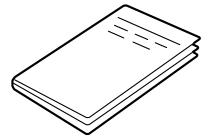

Quick Start Guide

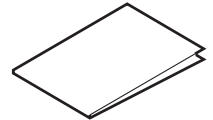

Remote Control Engine Starter Attachment Kit P/N 08E92-T0A-100A

Control unit bracket

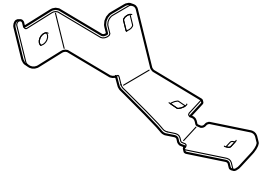

Engine starter harness

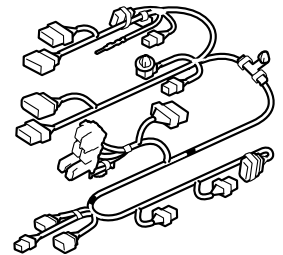

3 Relays

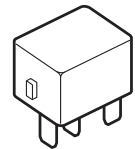

8 mm Nut



20 Wire ties

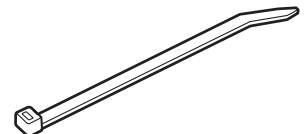

Long wire tie

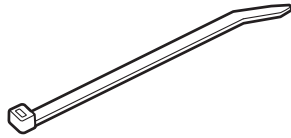

7 Urethane tapes

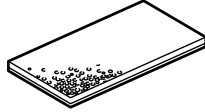

Template

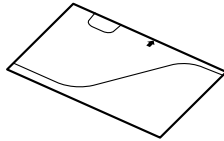

Clip

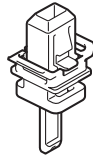

TOOLS AND SUPPLIES REQUIRED

Phillips screwdriver
Diagonal cutters
Ratchet
8 mm, 10 mm, and 12 mm Sockets
Combination wrench
Isopropyl alcohol
Scissors
Small flat-tip screwdriver
Shop towel
Ruler
Tape measure
HDS (Honda Diagnostic System)
Needle nose pliers
Masking tape
Electrical tape
The following tool is available through the Honda Tool and Equipment Program. On the iN click on: Service > Service Bay > Tool and Equipment Program, the enter the number under search. Or call 888-424-6857.
Trim Tool Set (T/N SOJATP2014)

Illustration of the Remote Control Engine Starter on the Vehicle

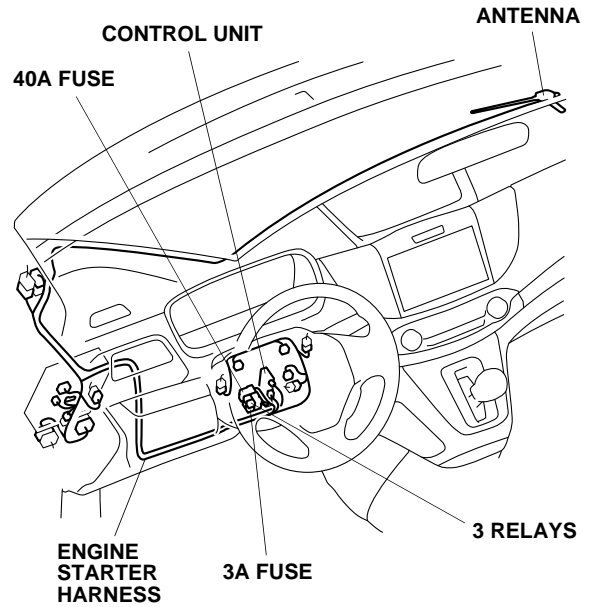

INSTALLATION

Customer Information: The information in this installation instruction is intended for use only by skilled technicians who have the proper tools, equipment, and training to correctly and safely add equipment to your vehicle. These procedures should not be attempted by “do-it-yourselfers.”

NOTE: This antenna should only be installed if the ambient air temperature 15°C (60°F) or above.

1. Move the driver's seat all the way back.
2. Disconnect the negative cable from the battery.

Setting the Control Unit

- Using a small flat-tip screwdriver, set the switches on the (accessory) control unit to the locations shown.

NOTE:

- The switches must be set before the control unit is plugged in.
- If the switch settings are not correct, the remote engine starter will not operate correctly.
- If setting the switches with the control unit installed in the vehicle, touch the metal part of the screwdriver to any metal part of the vehicle to discharge any static electricity.
- If you change the switch settings with the unit connected, you must disconnect the unit, then reconnect it before the new settings are recognized.

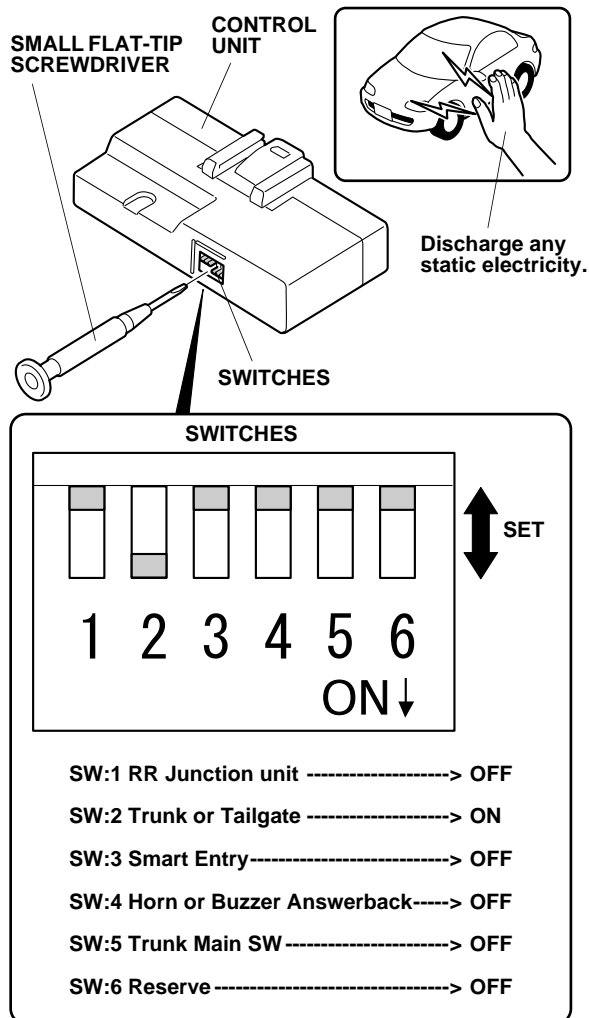

- Using isopropyl alcohol on a shop towel, clean the control unit where the protective tape will attach. Remove the adhesive backing, and attach the protective tape to the control unit over the switches.

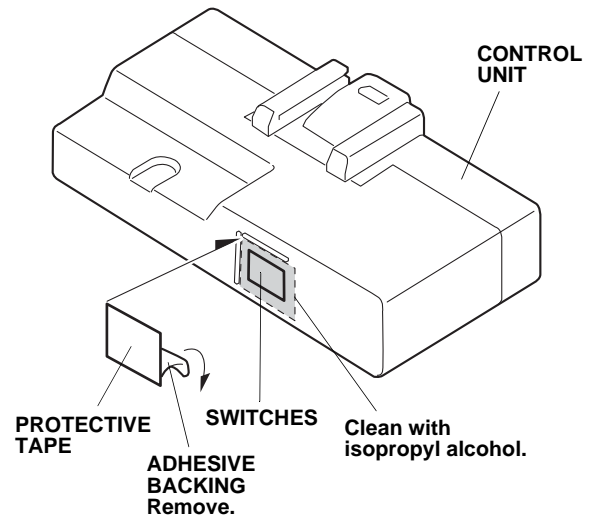

Removing the Vehicle Parts

- Remove the roof console.
 - Using a plastic trim tool, pry out and remove the left and right lens (four retaining tabs each).
 - Open the sunglass holder and remove the four screws.
 - Remove the roof console (unplug the vehicle connectors).

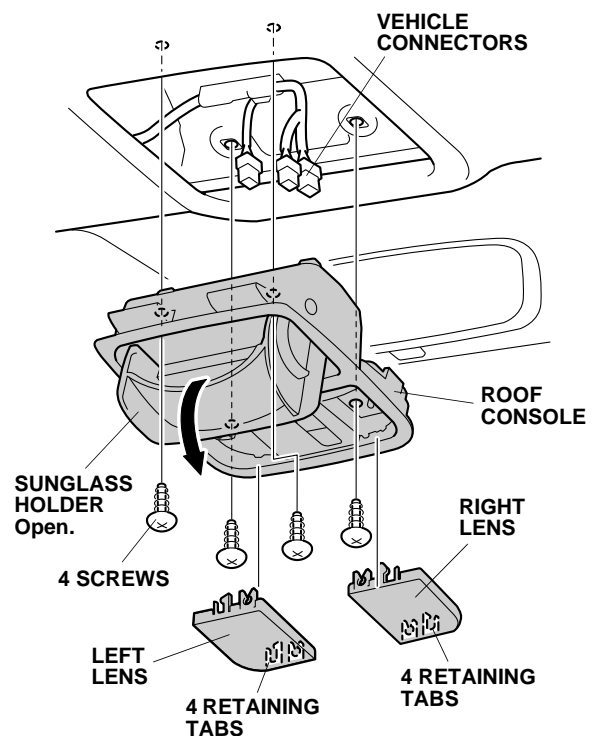

- Release the driver's sunvisor and passenger's sunvisor from the two sunvisor holders.

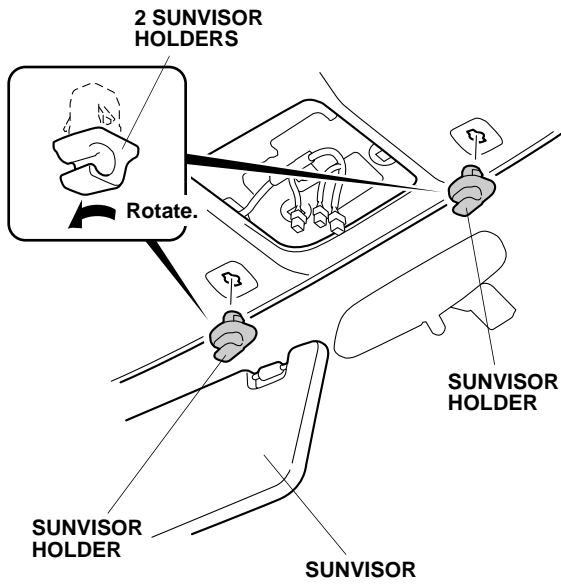

- Rotate each sunvisor holders 45° counterclockwise to remove the two sunvisor holders.
- Pull away the driver's door opening seal from the driver's A-pillar. Gently pull out the driver's A-pillar trim to release the clips.

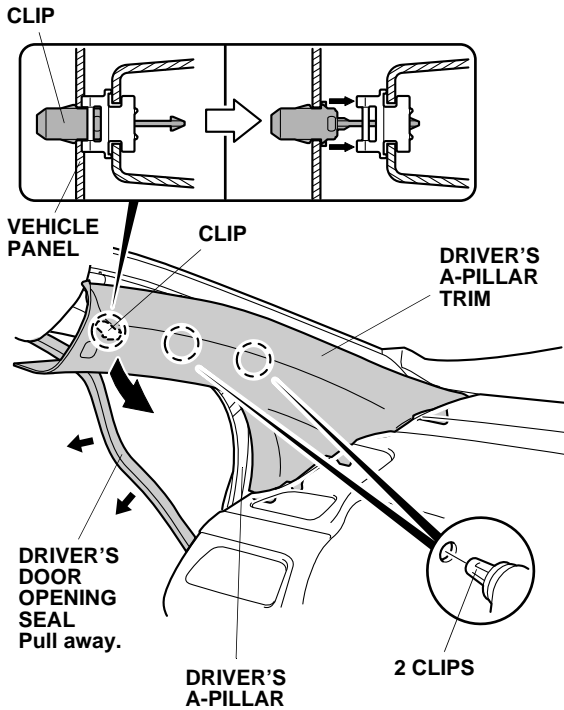

- To prevent the clips from falling into the vehicle body, roll up the shop towel, and insert it between the driver's A-pillar and the dashboard. Take care not to damage the driver's A-pillar.

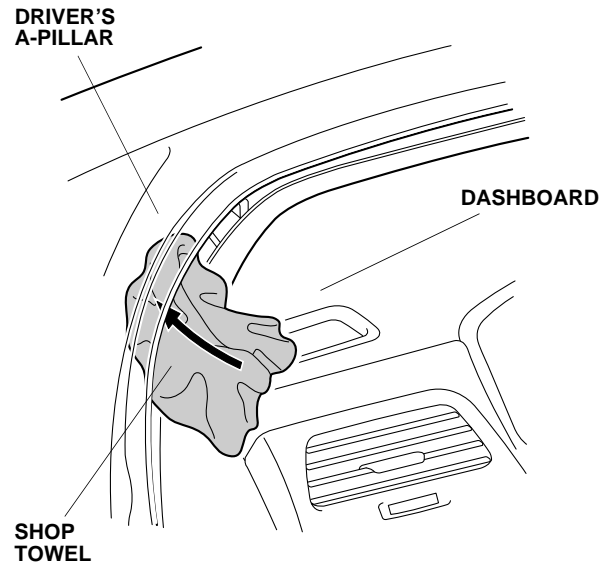

- Remove the driver's A-pillar trim. Carefully remove the shop towel and any clips that fell from the driver's A-pillar trim.
NOTE: The upper clip will stay in the body.

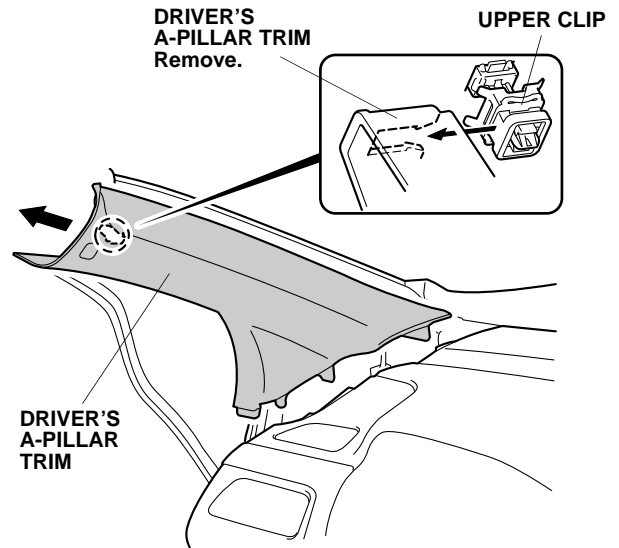

- Remove the remaining upper clip from the driver's A-pillar.

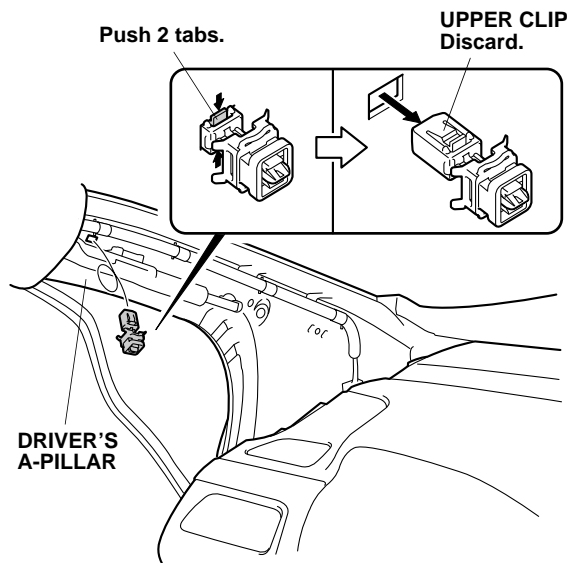

- Temporarily reinstall the driver's A-pillar trim, and check the overlap between the headliner and the driver's A-pillar trim according to the service manual. Remove the driver's A-pillar trim. Install the new clip (supplied) to the driver's A-pillar trim.

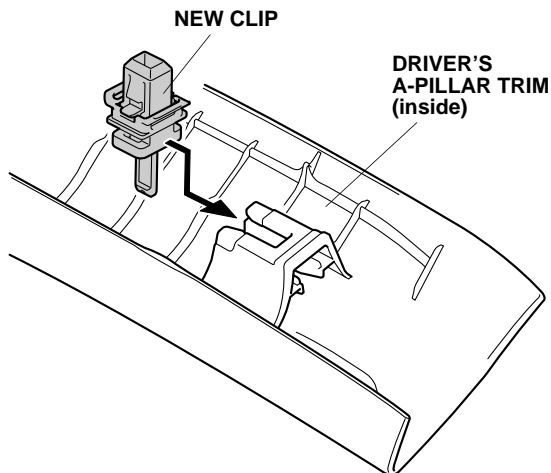

- Remove the driver's dashboard panel (six clips and unplug the vehicle connector).

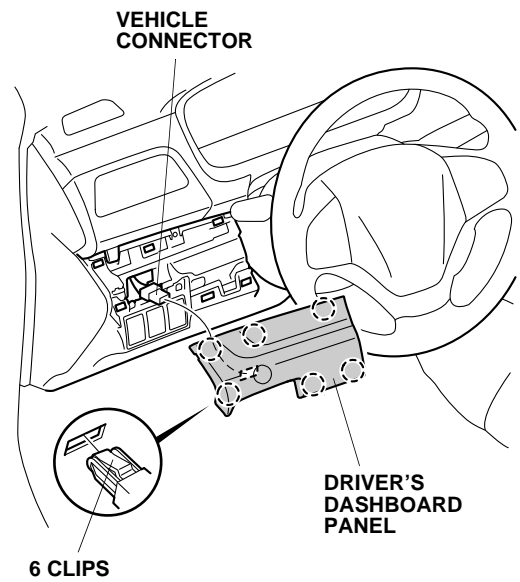

- Remove the driver's air outlet (one self-tapping screw, one retaining tab, and three clips).

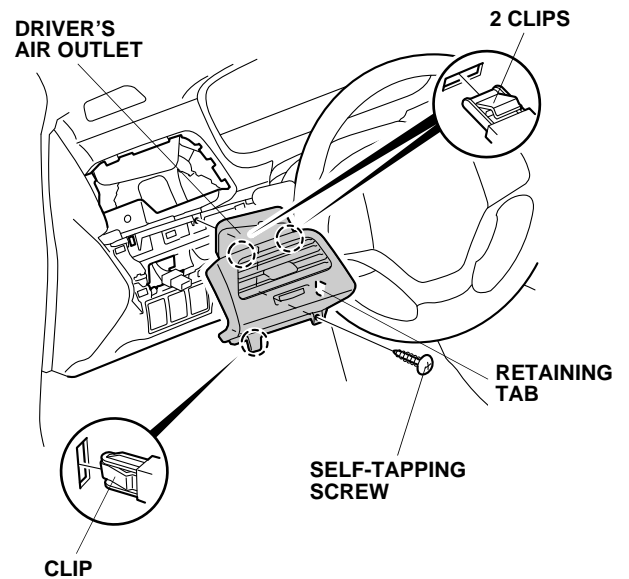

15. Remove the driver's dashboard under cover (turn the knob, one clip and one pin).

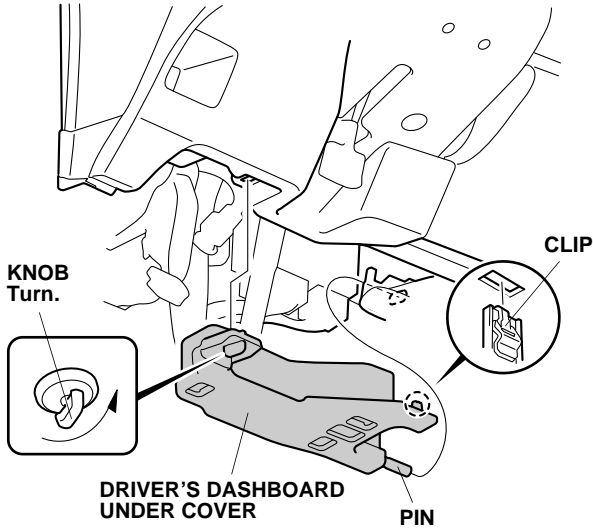

16. Remove the driver's dashboard lower cover (eight clips and unplug the vehicle connector).

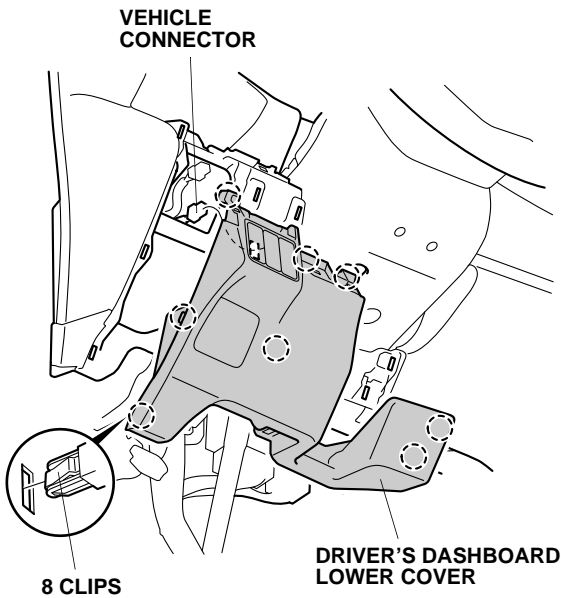

17. Attach the masking tape to the upper column cover as shown.

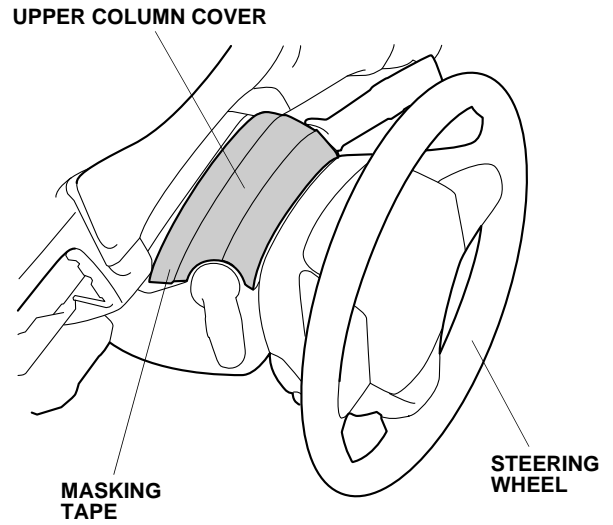

18. Lower the tilt lever, and turn the steering wheel 90° counterclockwise.

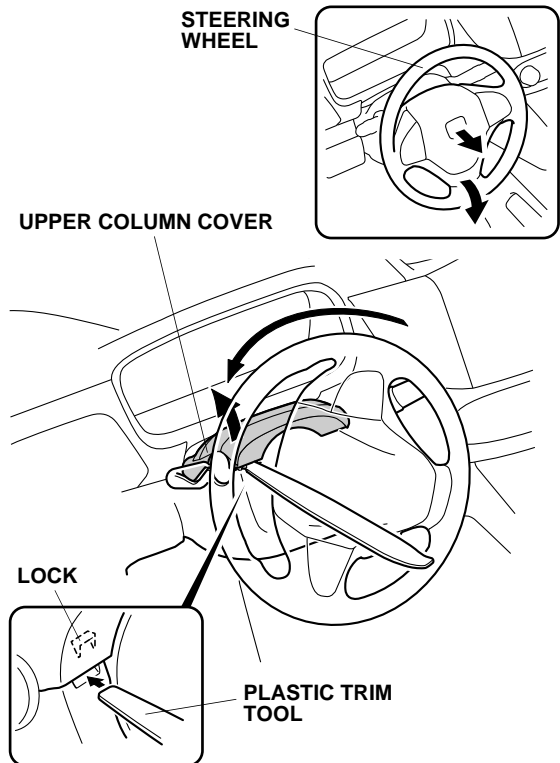

19. Using a plastic trim tool, release the lock as shown.

20. Turn the steering wheel 180° clockwise. Using a plastic trim tool, release the lock as shown.

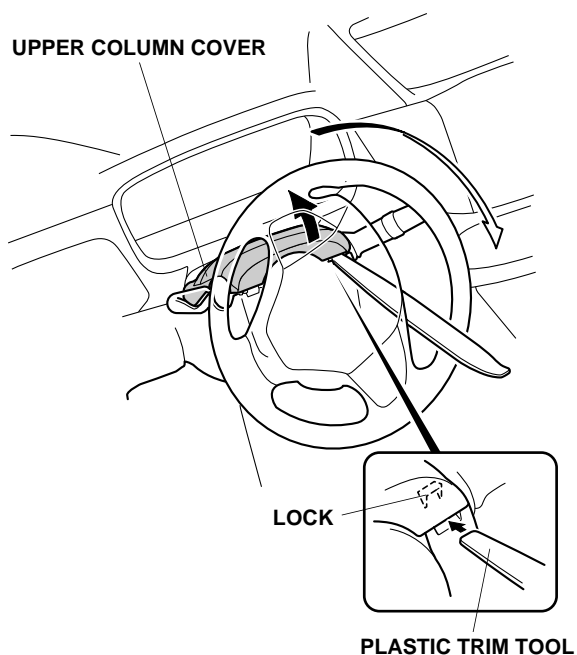

21. Secure the upper column cover to the meter panel with the tape.

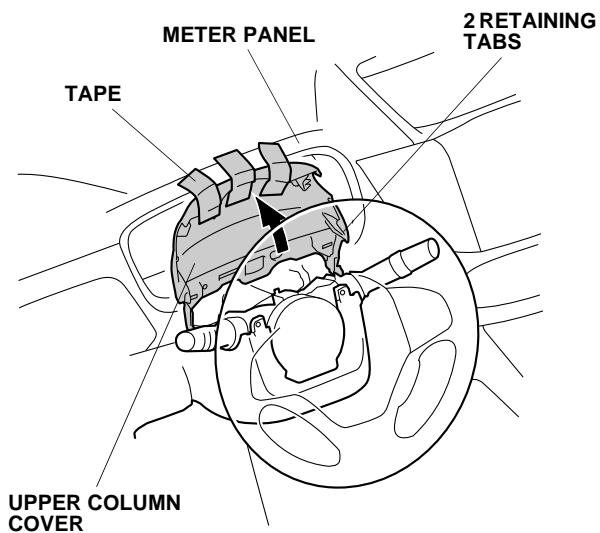

22. Remove the two self-tapping screws from the lower column cover.

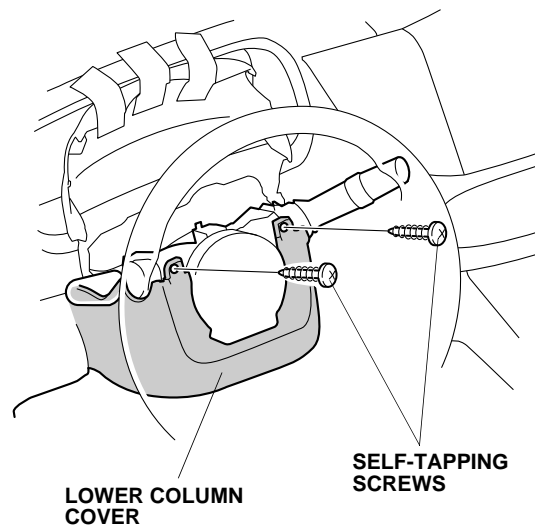

23. Remove the lower column cover (one self-tapping screw).

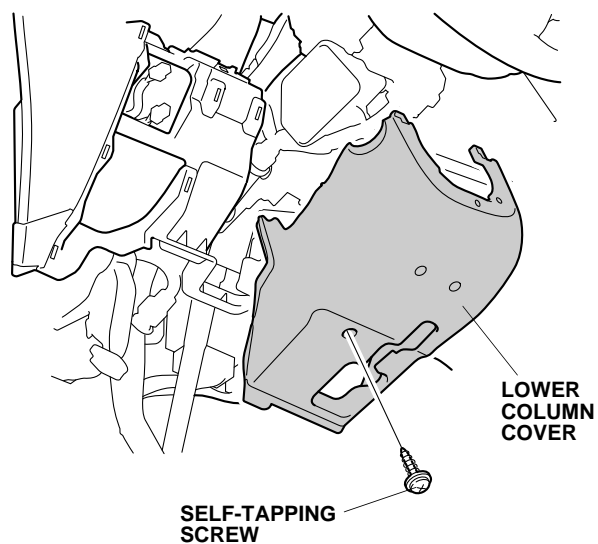

24. Remove the driver's front door sill trim (two retaining tabs, three clips, and two hooks).

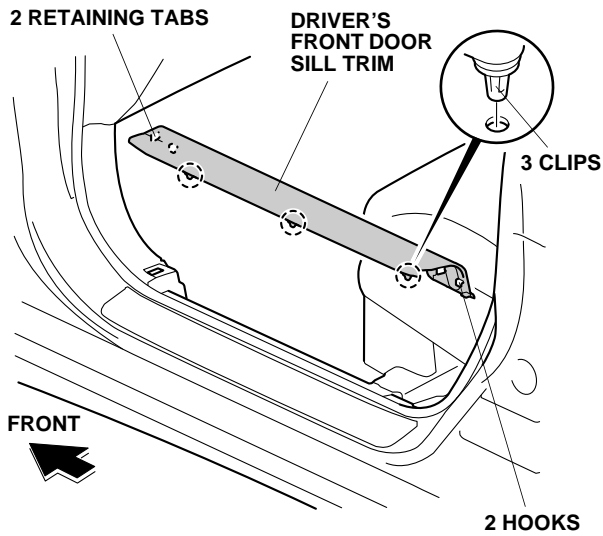

25. Pull away the driver's door opening seal, and remove the driver's kick panel (two clips).

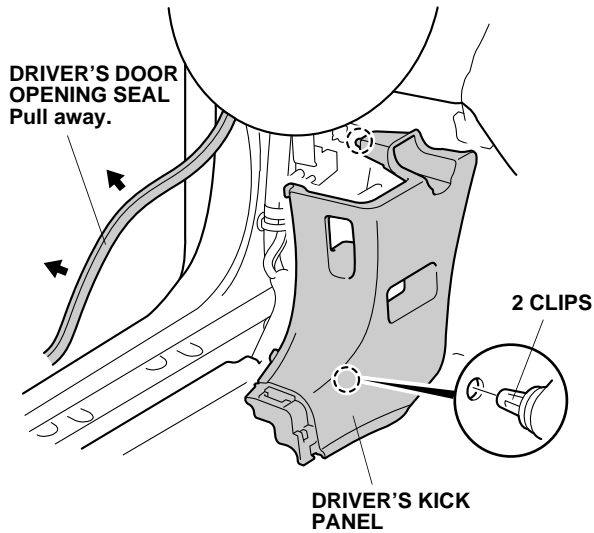

Installing the Antenna

26. Using the two pairs of needle nose pliers, bend the antenna plate according to the full scale drawing as shown.

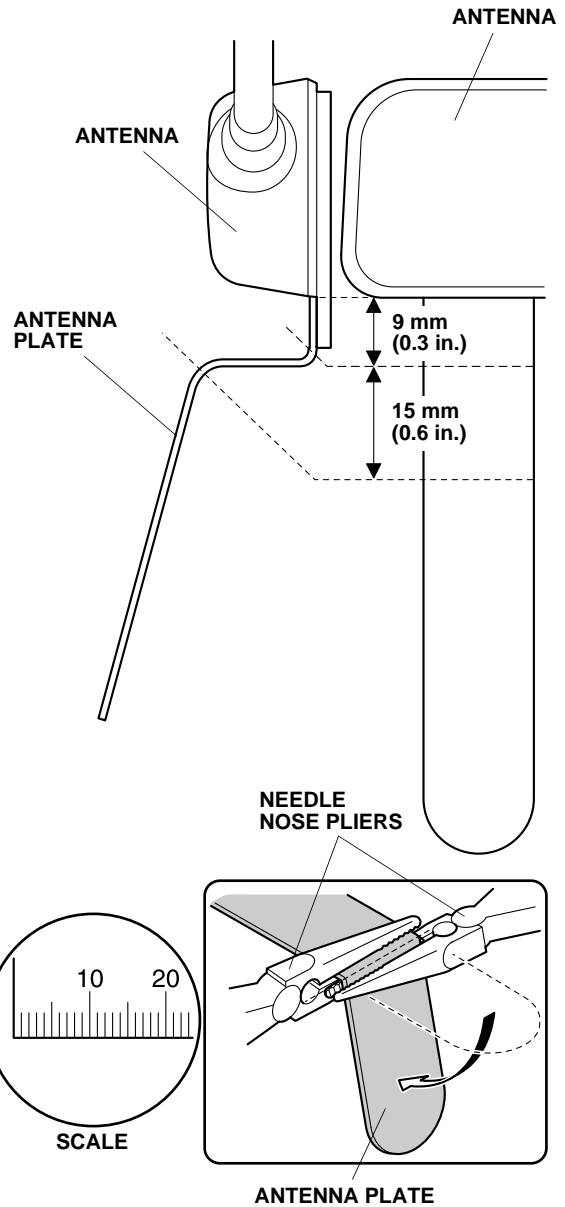

27. Using scissors, cut out the template.

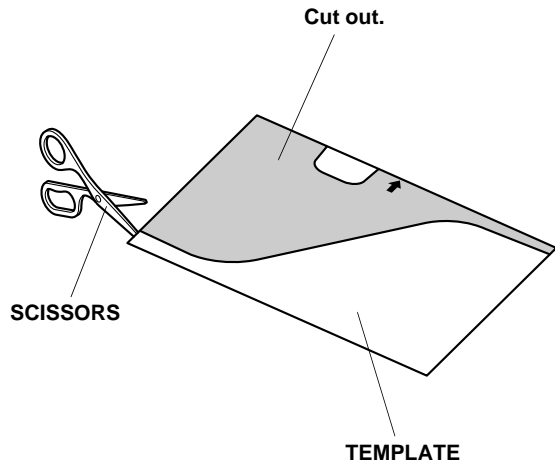

28. Using the strips of masking tape, attach the template to the front windshield. Align the template with the black ceramic paint as shown.

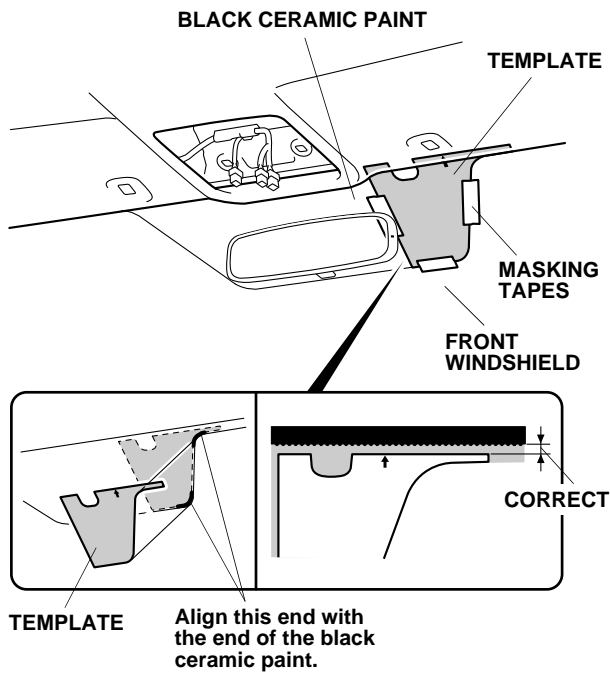

29. Starting from the antenna end of the antenna cable, wrap three urethane tapes to the antenna cable at the measurements shown.

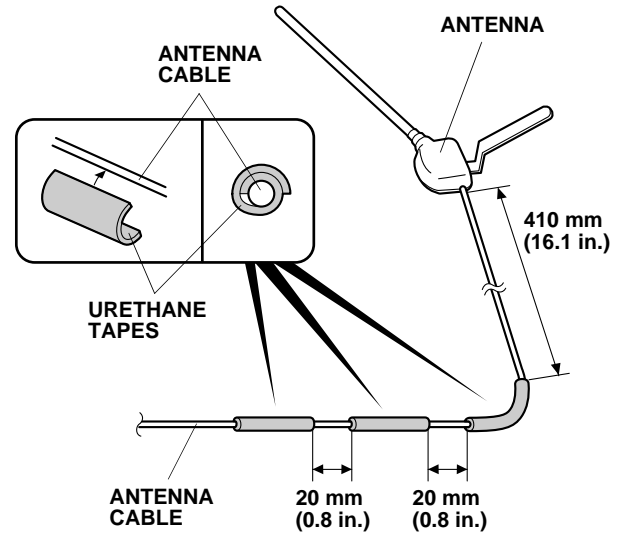

30. Using isopropyl alcohol on a shop towel, thoroughly clean the area where the antenna will attach.

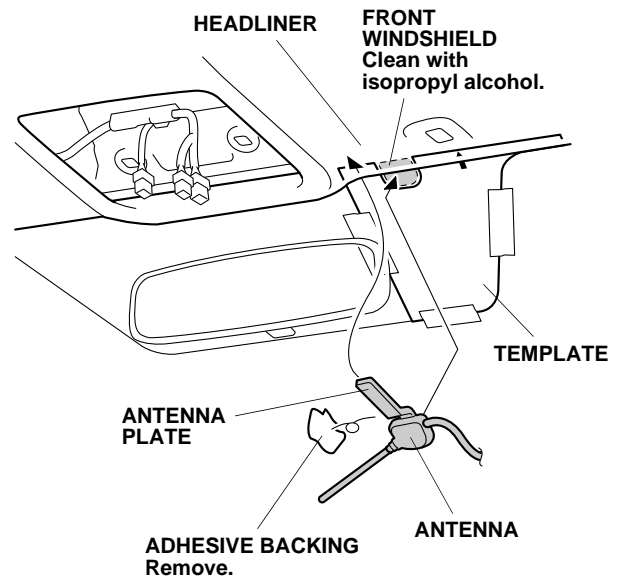

31. Remove the adhesive backing from the antenna. Insert the antenna plate under the headliner, align the antenna with the template, and attach the antenna to the front windshield. Press the antenna firmly for 30 seconds.

32. Remove the template.

33. Gently pull down the headliner, and tuck the antenna cable under the headliner. Be careful not to crease the headliner.

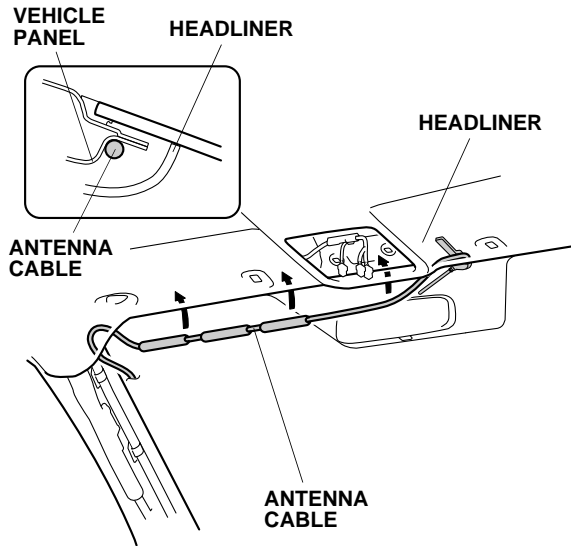

34. Using isopropyl alcohol on a shop towel, thoroughly clean the vehicle panel, where the urethane tapes will attach.

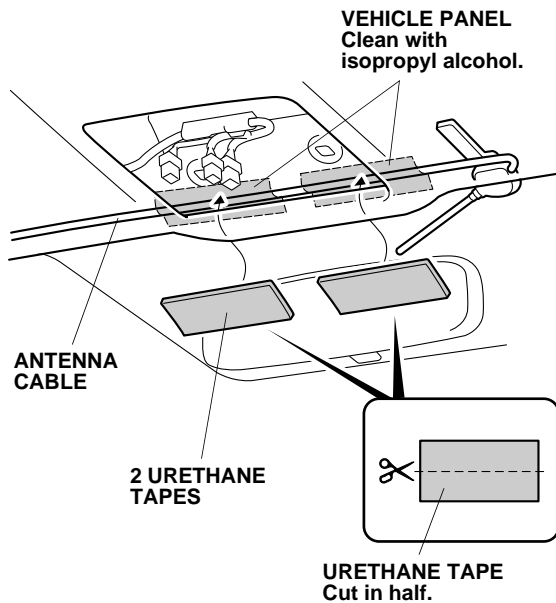

35. Using scissors, cut one urethane tape in half. Secure the antenna cable to the vehicle panel with two cut pieces of urethane tape. Be careful not to crease the headliner.

36. Route the antenna cable down the driver's A-pillar along the vehicle harness.

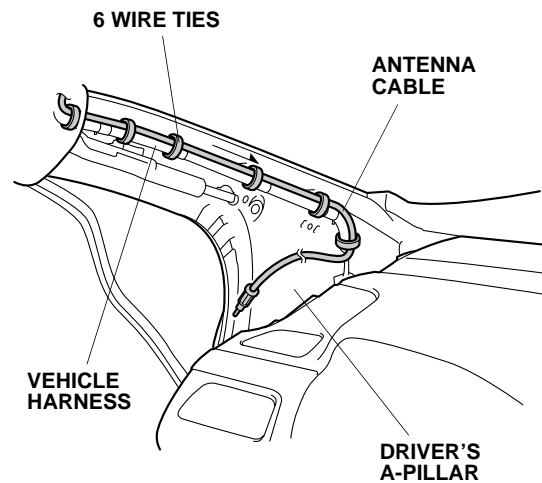

37. Secure the antenna cable to the vehicle harness with six wire ties.

38. Route the antenna cable down behind the dashboard.

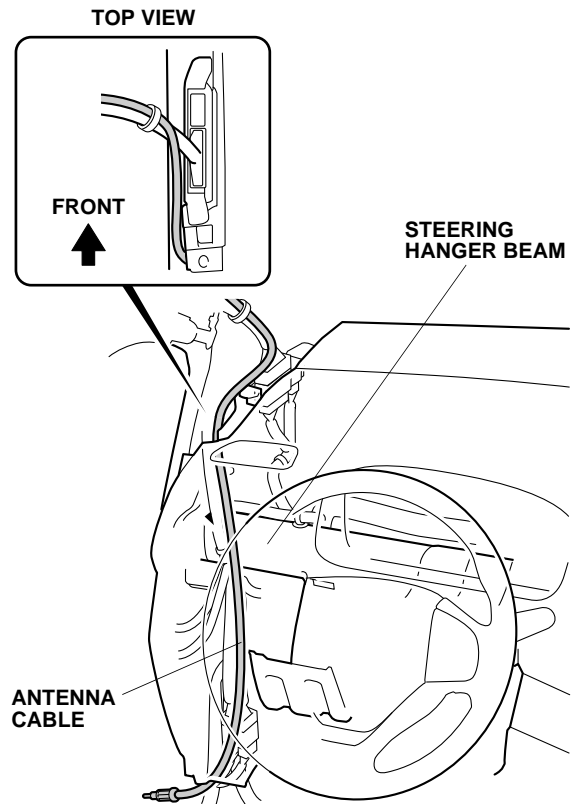

Routing the Engine Starter Harness

- Plug the three relays into the relay block on the engine starter harness.

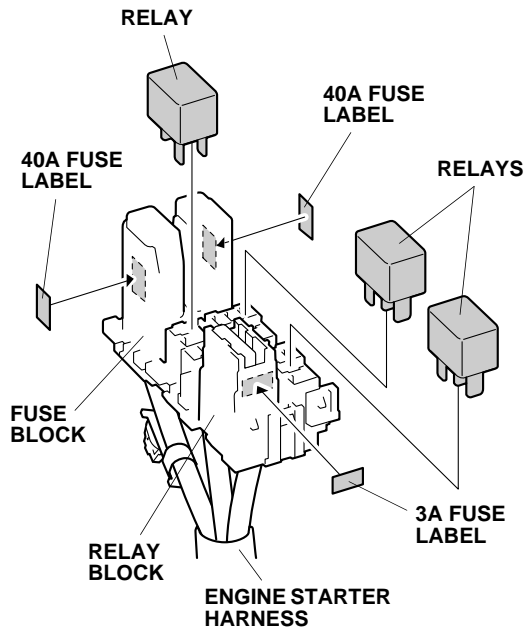

- Using isopropyl alcohol on a shop towel, thoroughly clean the relay block and fuse block where the 3A fuse label and 40A fuse labels will attach.
- Attach the 3A fuse label and two 40A fuse labels to the relay block and fuse block on the engine starter harness.
- Route the two 28-pin connectors of the engine starter harness upward as shown.

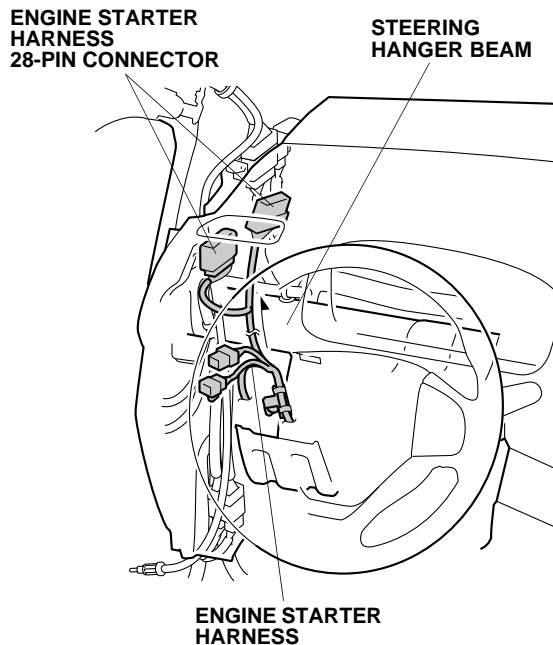

- Unplug the vehicle 28-pin connector.

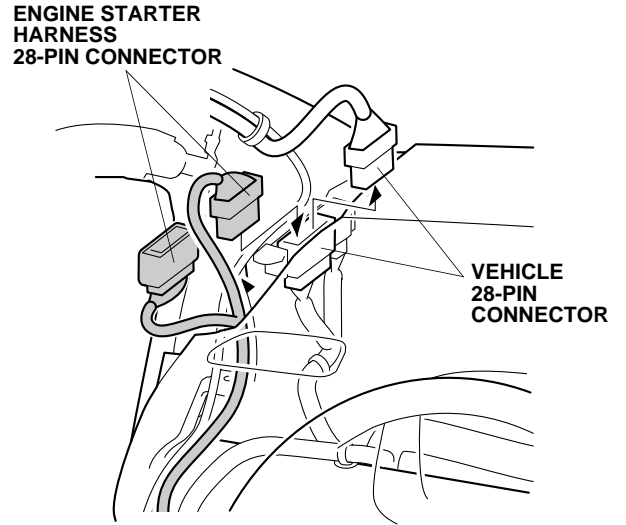

- Route the engine starter harness 28-pin connectors as shown, and plug the engine starter harness 28-pin connector into the vehicle 28-pin connector.
- Push the engine starter harness 28-pin connector between the driver's A-pillar and vehicle 28-pin connector as shown.

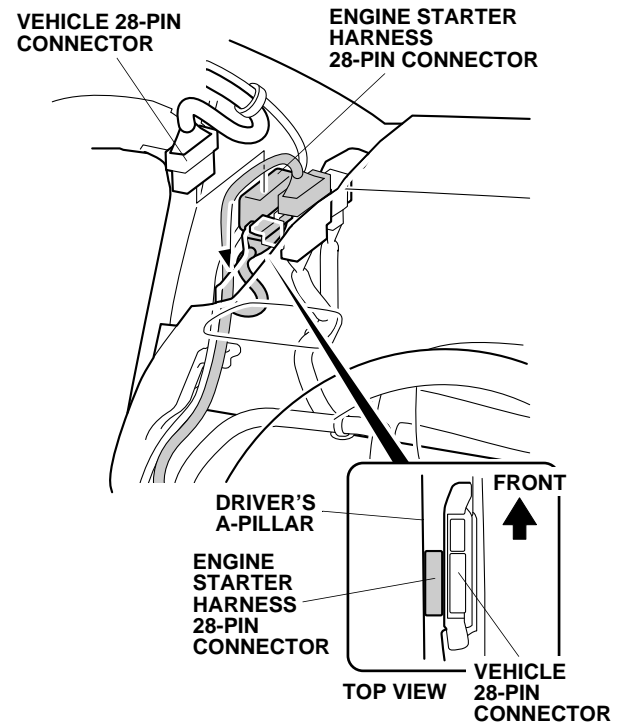

- Plug the vehicle 28-pin connector into the engine starter harness 28-pin connector.

47. Secure the engine starter harness and the antenna cable to the vehicle frame with one wire tie.

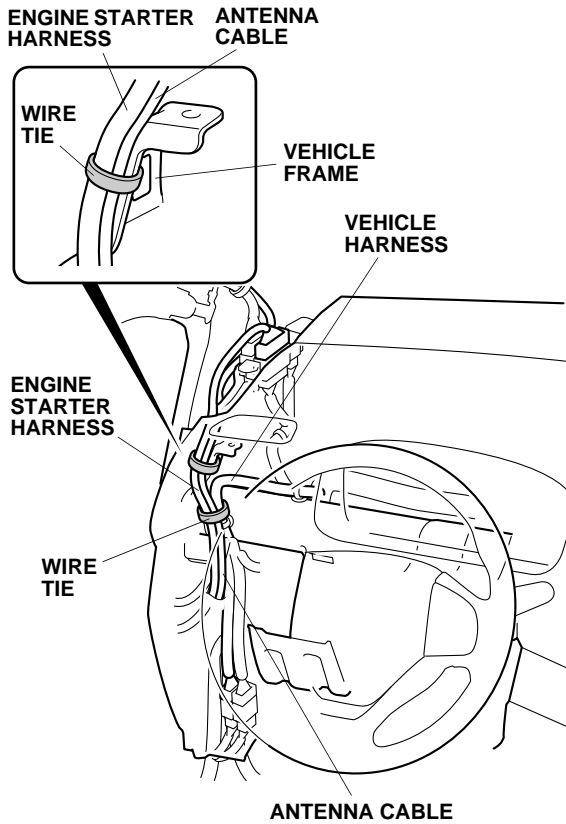

48. Secure the engine starter harness and the antenna cable to the vehicle harness with one wire tie.

49. Unplug the vehicle 5-pin connector from the fuse box, and plug it into the engine starter harness 5-pin connector.

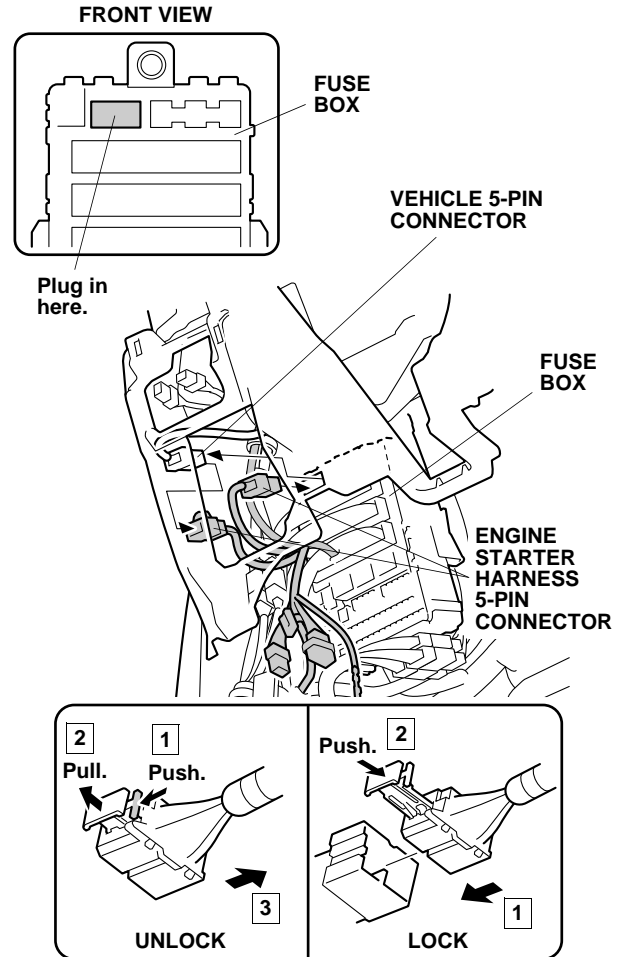

50. Plug the remaining engine starter harness 5-pin connector into the fuse box.
 NOTE: Check that the engine starter harness 5-pin connector is securely connected to the fuse box 5-pin connector. A loose connection can cause the engine to stall.

51. Attach the connector clip from the engine starter harness 5-pin connector to the hole in the vehicle panel.

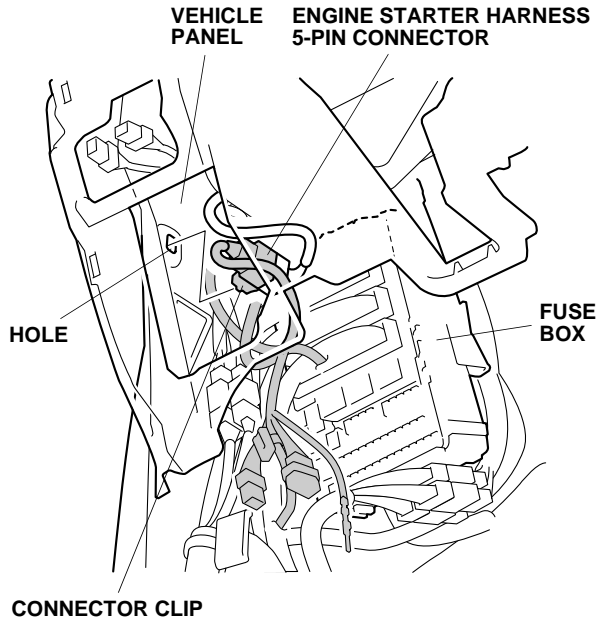

52. Slide the other clip on the engine starter harness onto the vehicle connector. Note the direction and the orientation of the clip.

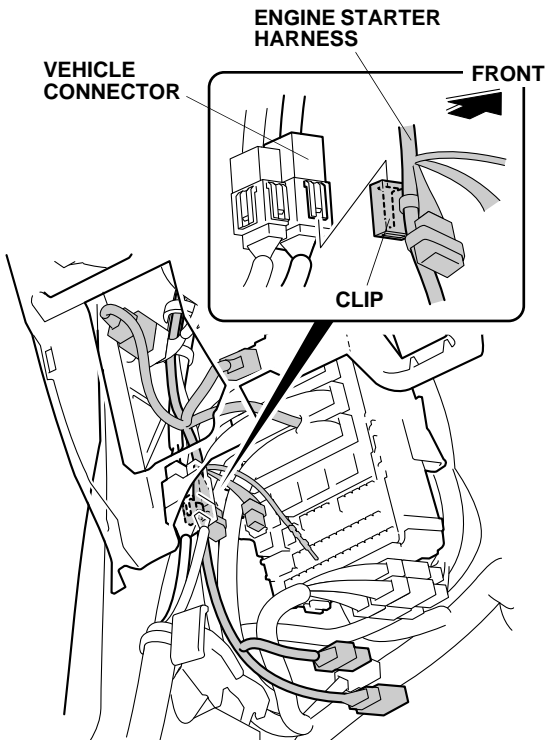

If the vehicle is equipped with the accessory fog lights, go to step 54; otherwise, continue with step 53.

53. Plug the engine starter harness 4-pin connector into the fuse box. Go to step 56.

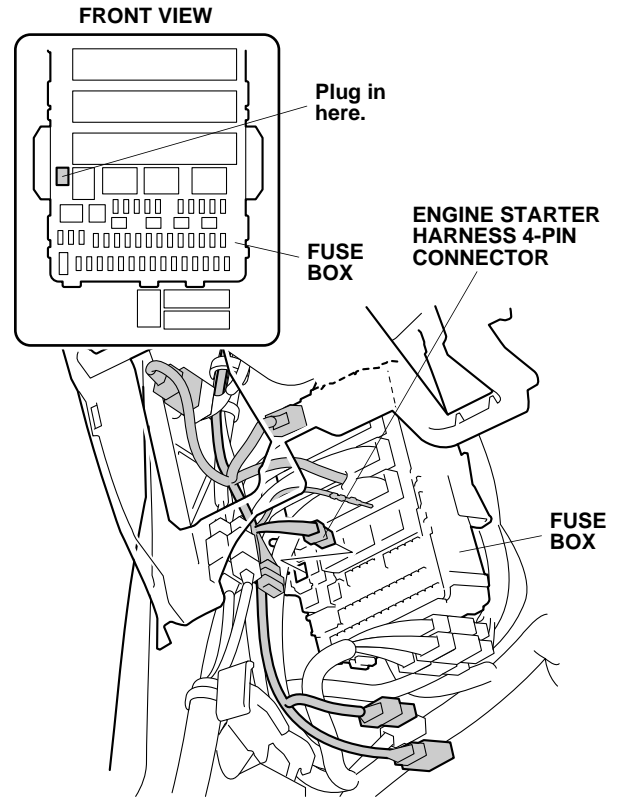

54. Unplug the fog light 4-pin connector from the fuse box, and plug it into the engine starter harness 4-pin connector.

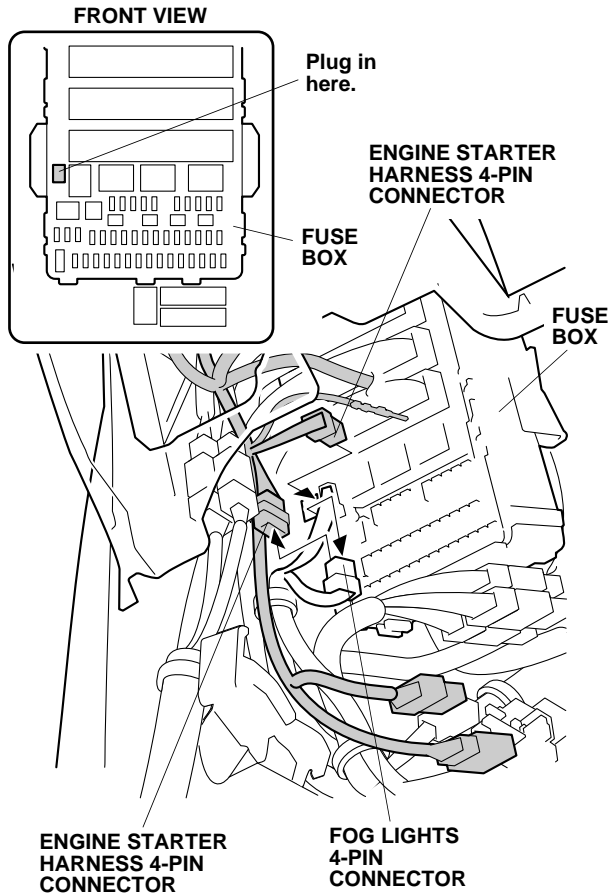

55. Plug the remaining engine starter harness 4-pin connector into the fuse box.

56. Unplug the vehicle 38-pin connector from the fuse box as shown.

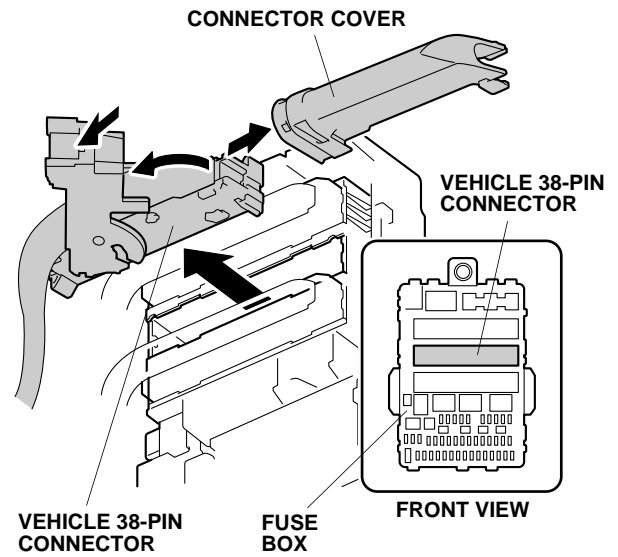

57. Remove the connector cover.
58. Remove the lever from the vehicle 38-pin connector as shown.

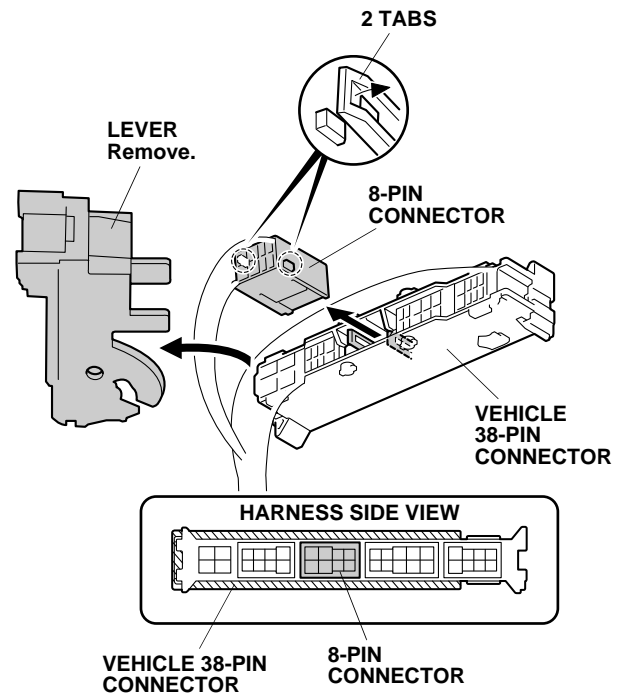

59. Remove the 8-pin connector from the vehicle 38-pin connector (two tabs).

60. Release the retainer from the 8-pin connector.

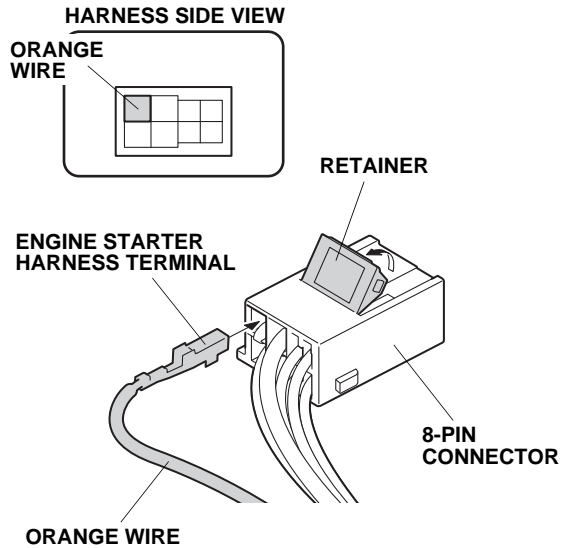

61. Insert the engine starter harness terminal (orange wire) into the 8-pin connector. Reinstall the 8-pin connector and lever.
62. Secure the engine starter harness to the vehicle harness with an electrical tape.

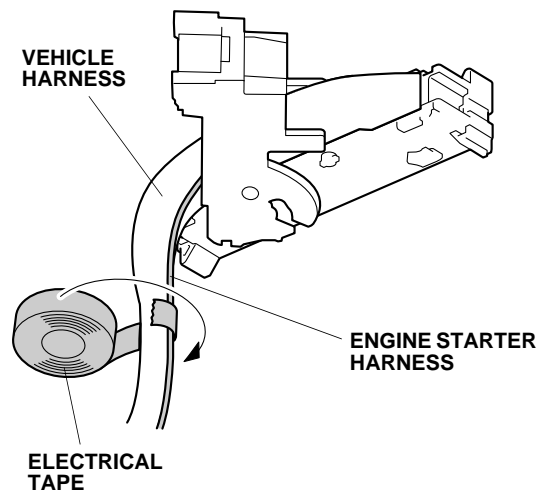

63. Reinstall the connector cover.
64. Plug the vehicle 38-pin connector into the fuse box.

65. Unplug the vehicle 24-pin connector, and plug the engine starter harness 24-pin connector into the vehicle 24-pin connector.

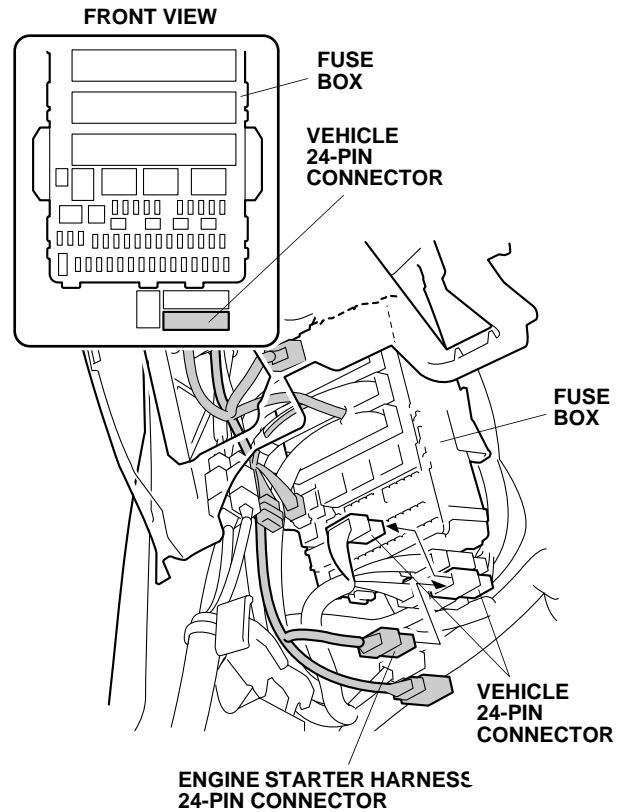

66. Slide the clip from the engine starter harness 24-pin connector onto the bottom of the fuse box, then plug the remaining vehicle 24-pin connector into the engine starter harness 24-pin connector.

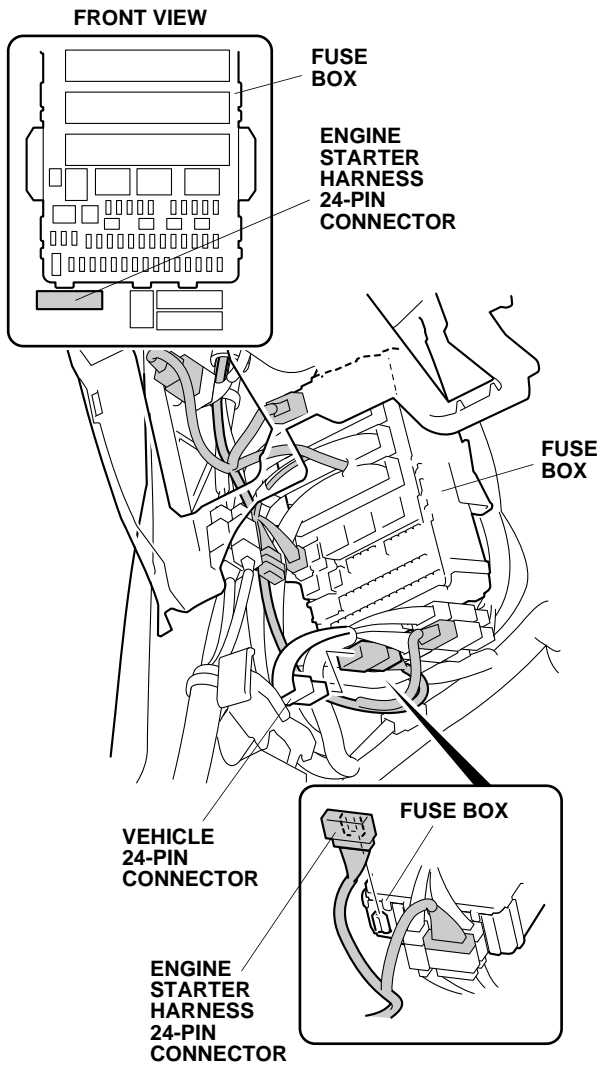

67. Secure the engine starter harness to the vehicle harness with two wire ties.

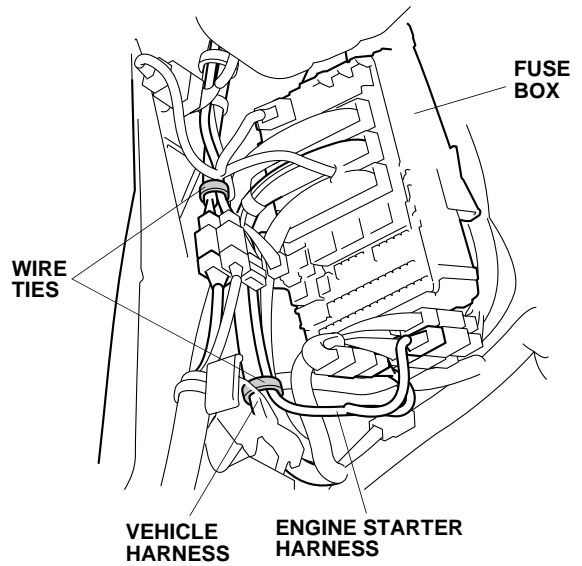

68. Route the engine starter harness under the dashboard and toward the steering wheel.

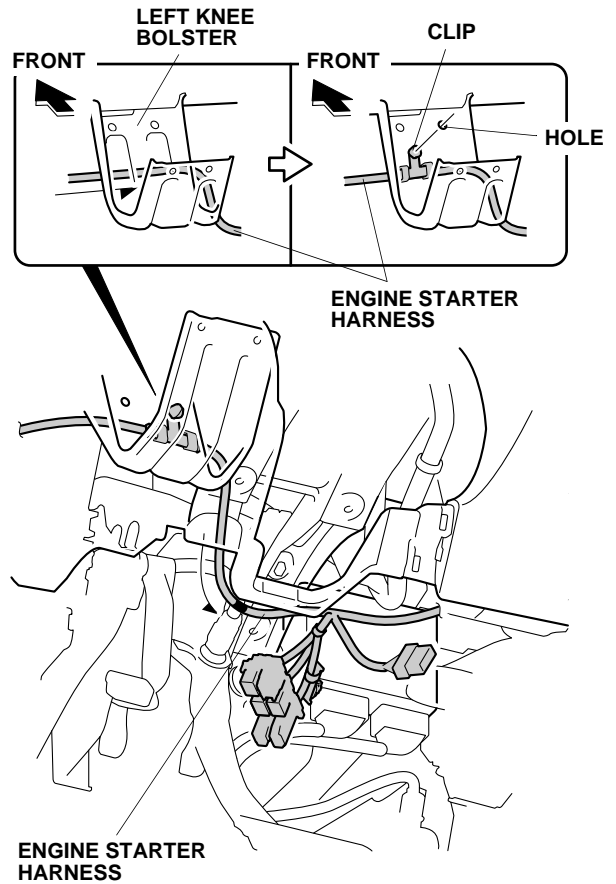

69. Secure the engine starter harness to the hole in the left knee bolster using the clip on the engine starter harness as shown.

70. Locate the white tape on the engine starter harness, and loosely secure the engine starter harness to the dashboard with one wire tie at the white tape.

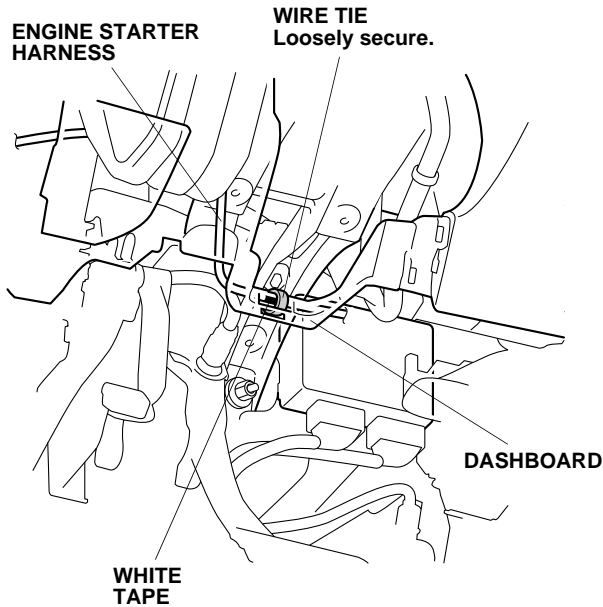

71. Route the engine starter harness up steering wheel as shown.

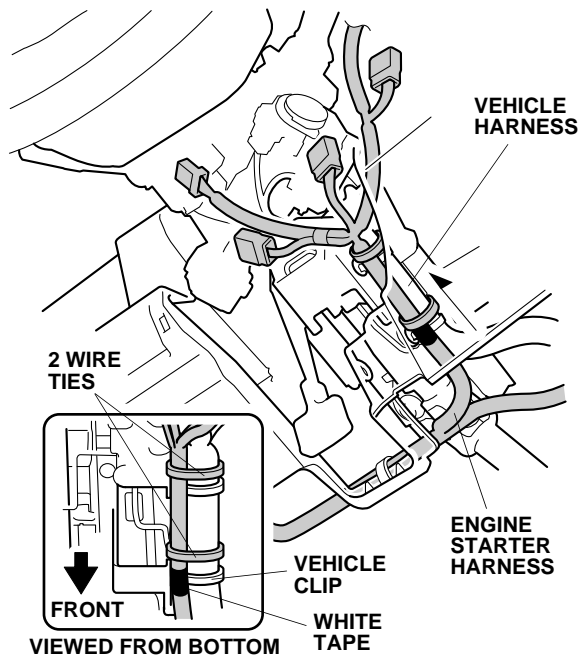

72. Align the white tape on the engine starter harness with the vehicle clip, and secure the engine starter harness to the vehicle harness with two wire ties as shown.

73. Unplug the vehicle 7-pin connector from the ignition switch, and plug it into the engine starter harness 7-pin connector (black).

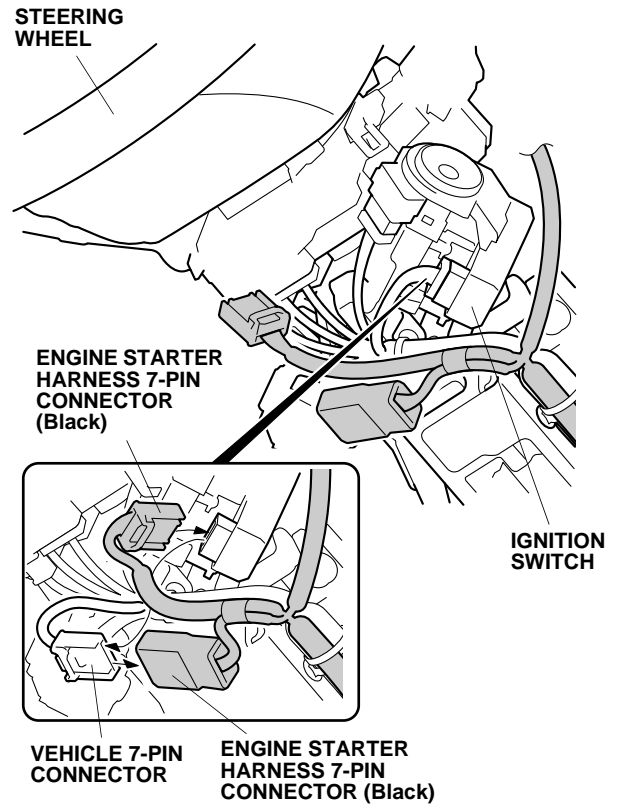

74. Plug the remaining engine starter harness 7-pin connector (black) into the ignition switch.
75. Secure the 7-pin connectors and engine starter harness to the vehicle harness with one wire tie.

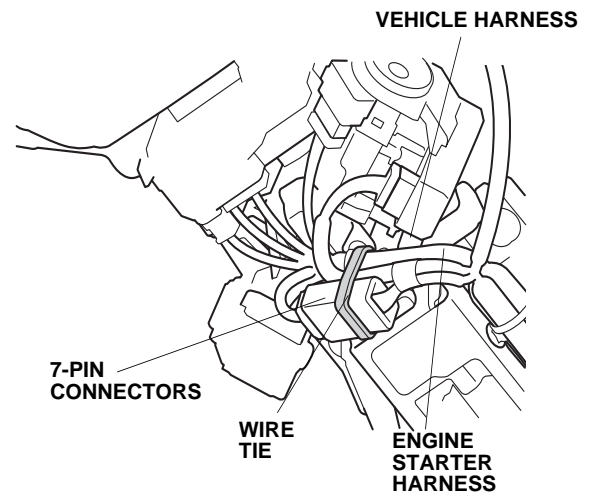

76. Route the engine starter harness across the steering column area as shown.

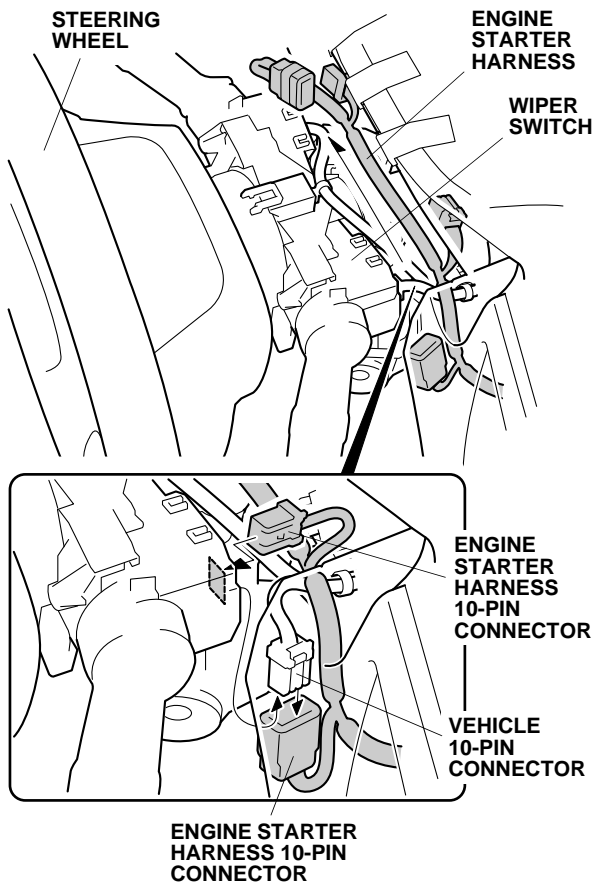

77. Unplug the vehicle 10-pin connector from the wiper switch, and plug it into the engine starter harness 10-pin connector.
78. Plug the remaining engine starter harness 10-pin connector into the wiper switch.

79. Secure the 10-pin connectors and engine starter harness to the vehicle harness with one wire tie.

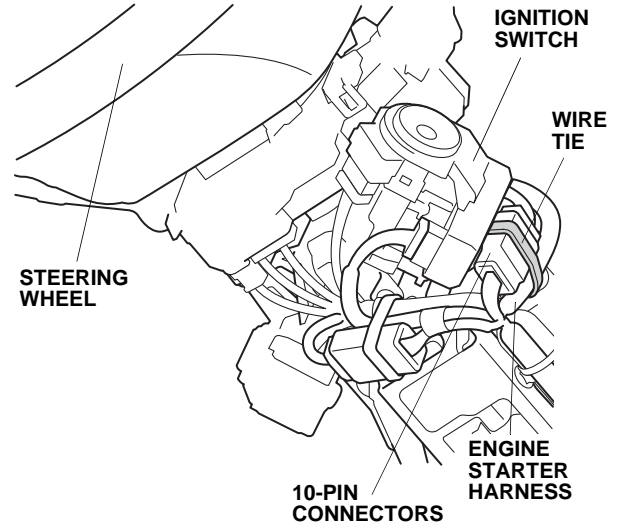

80. Unplug the vehicle 12-pin connector from the combination light switch, and plug it into the engine starter harness 12-pin connector.

COMBINATION LIGHT SWITCH

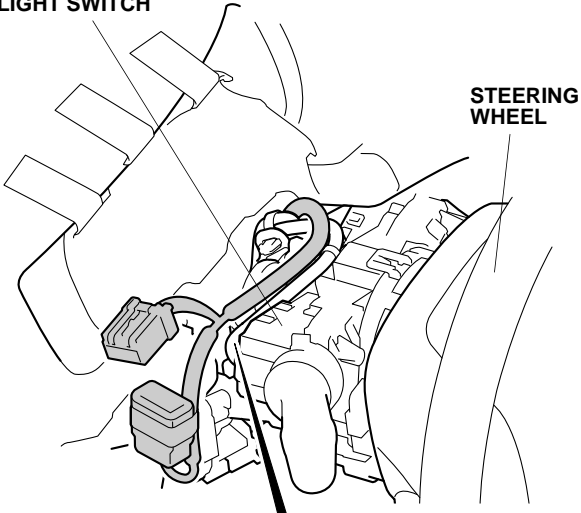

ENGINE STARTER HARNESS 12-PIN CONNECTOR

VEHICLE 12-PIN CONNECTOR

ENGINE STARTER HARNESS 12-PIN CONNECTOR

81. Plug the remaining engine starter harness 12-pin connector into the combination light switch.

82. Secure the engine starter harness to the vehicle harness with two wire ties. Check that the harness is secured without undue strain to the both left and right connector cords.

NOTE: Make sure that the connectors and harness are not pinched, or interfering with the steering wheel when adjusted.

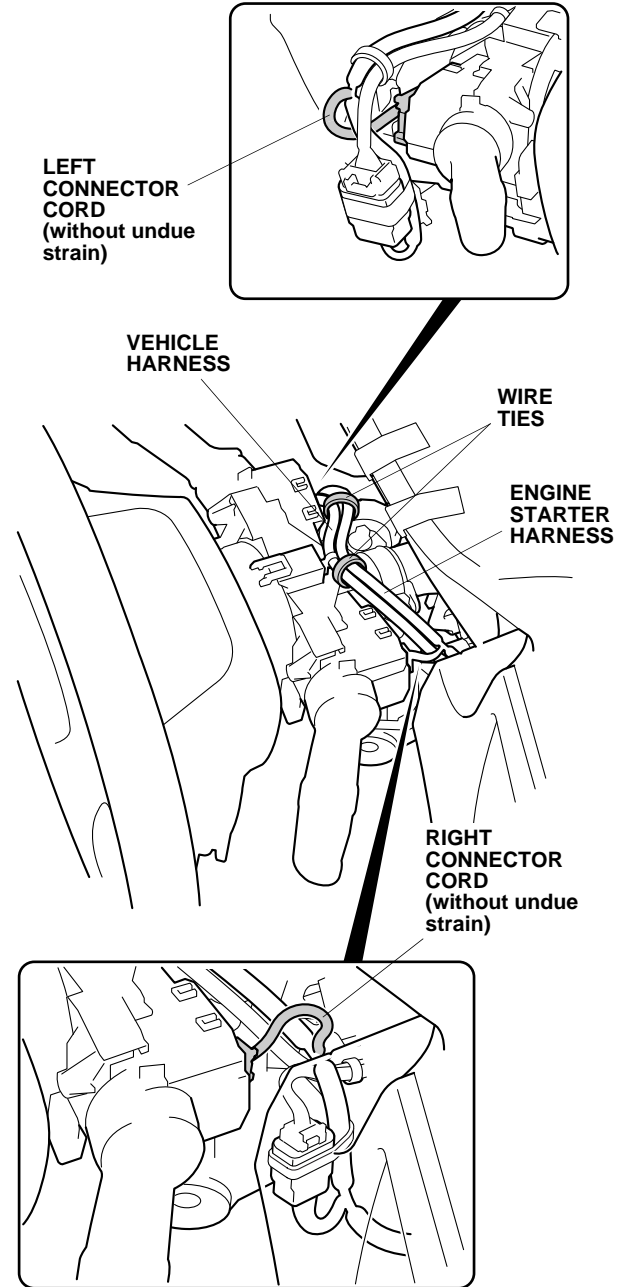

83. Route the antenna cable along the engine starter harness as shown.

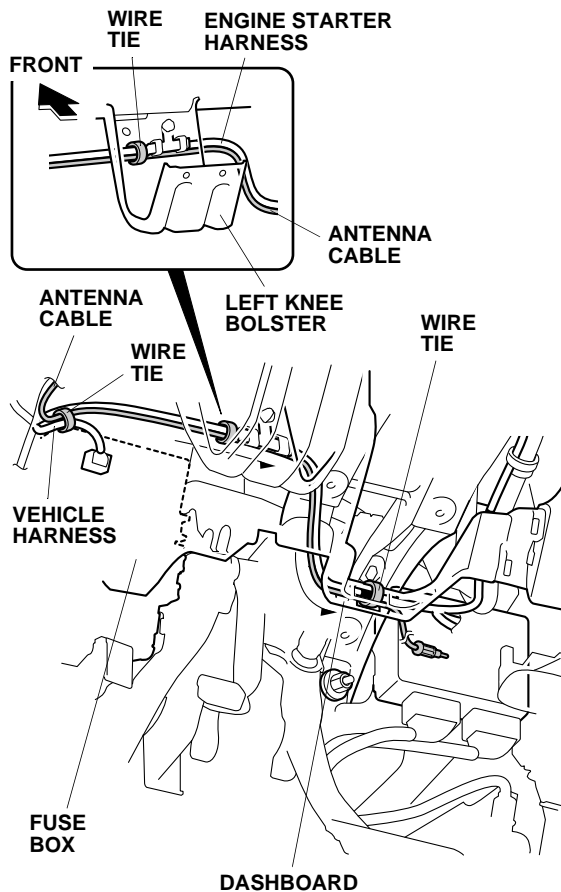

84. Secure the antenna cable to the engine starter harness with two wire ties.
85. Loosely secure the antenna cable to the dashboard with one wire tie loosely installed in step 70.

Installing the Control Unit

86. Using isopropyl alcohol on a shop towel, clean the area where the urethane tape will attach.

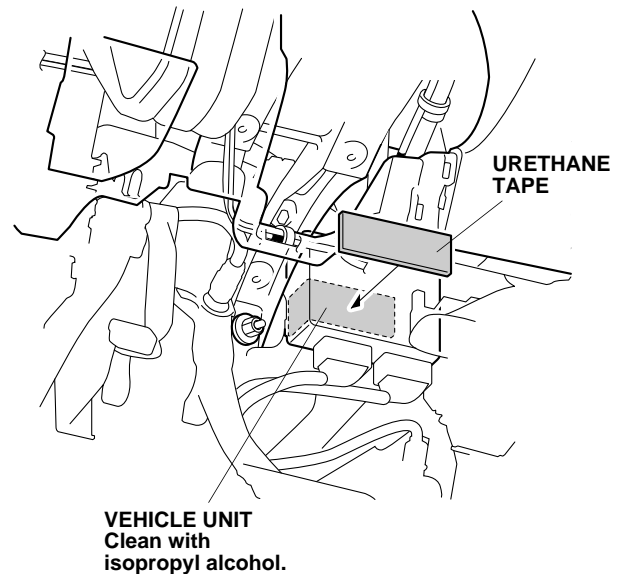

87. Attach the one urethane tape to the vehicle unit as shown.
88. Plug the antenna cable and the engine starter harness 28-pin connector into the control unit.

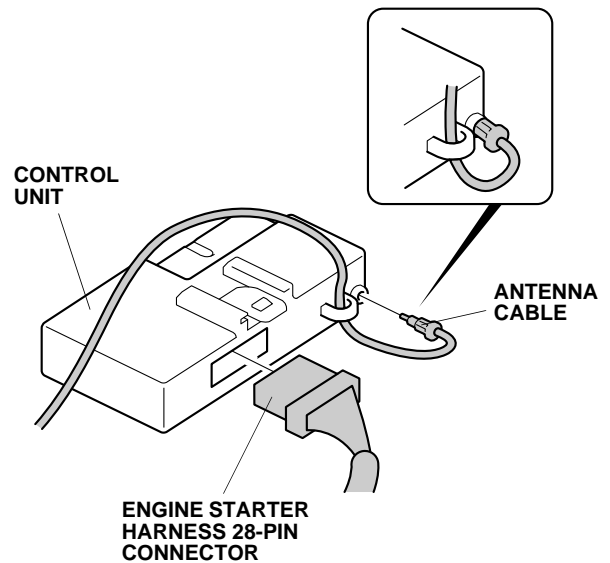

89. Install the control unit bracket to the control unit.

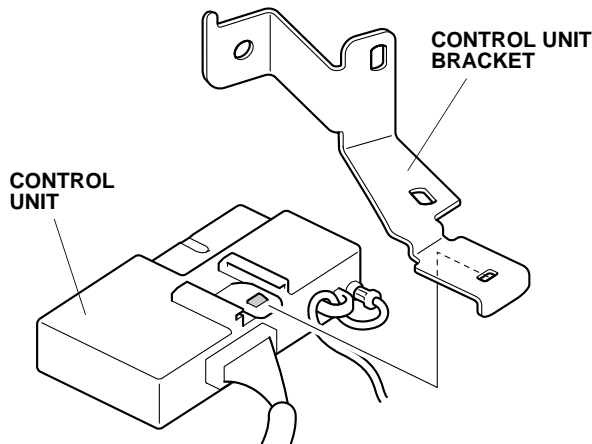

90. Secure the clip from the engine starter harness fuse block, and the clip from the engine starter harness into the holes in the control unit bracket.

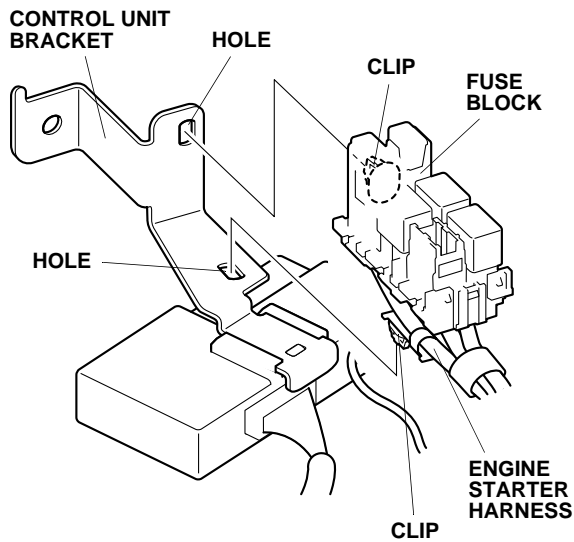

91. Remove the vehicle flange nut that secures the vehicle bracket.

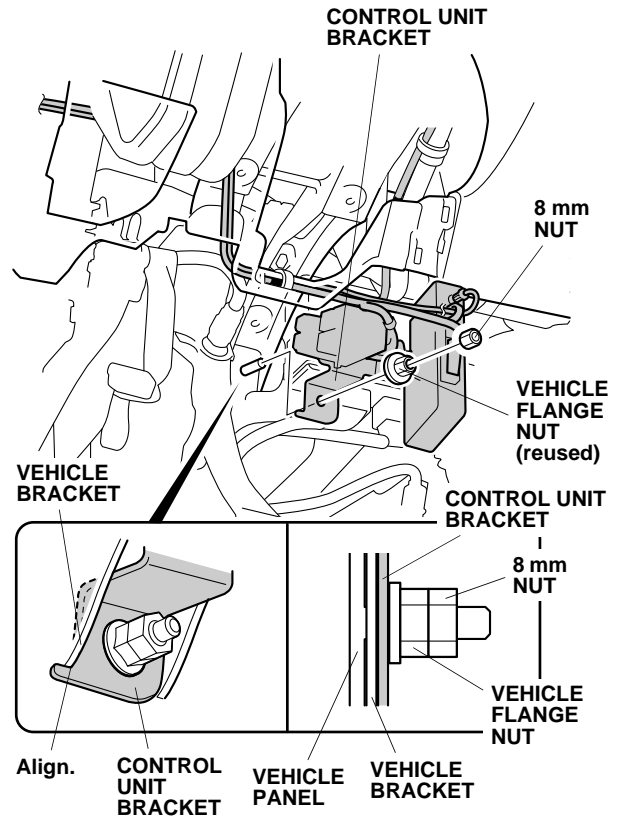

92. Install the control unit bracket on top of the vehicle bracket and align the control unit bracket with the edge of the vehicle bracket. Reinstall the vehicle flange nut. Install the 8 mm nut (supplied) on top of the vehicle flange nut.

93. Secure the antenna cable and engine starter harness to the vehicle harness with one long wire tie.

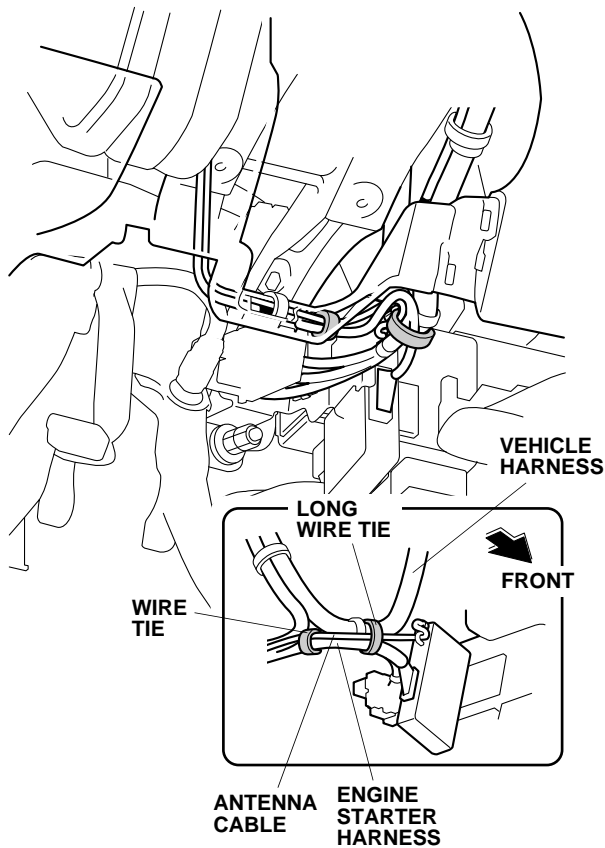

94. Secure the antenna cable to the engine starter harness with one wire tie.
95. Bundle up the excess antenna cable, and secure it to the dashboard with the one wire tie loosely installed in step 85.

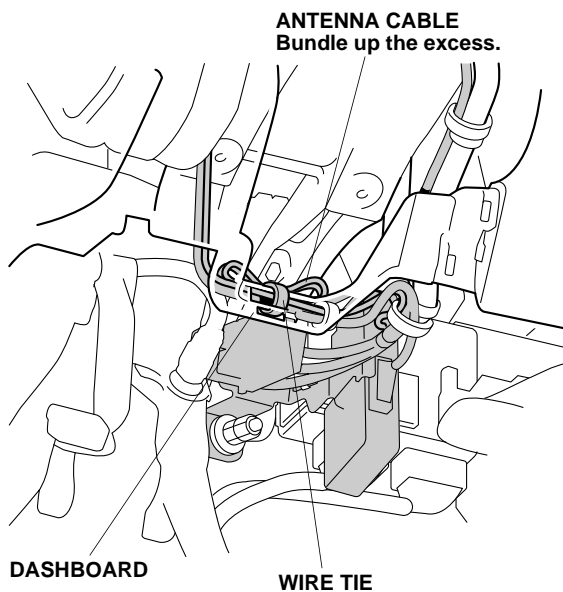

96. Using isopropyl alcohol on a shop towel, clean the areas where the urethane tapes will attach.

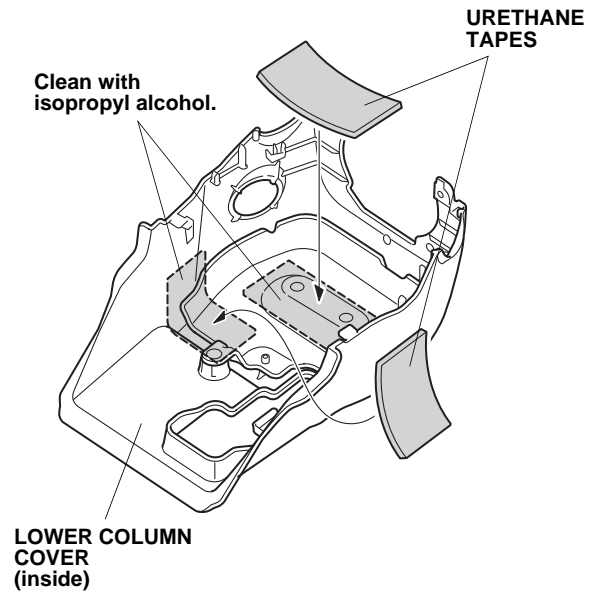

97. Attach the two urethane tapes to the inside of the lower column cover.
98. Open the hood. Using isopropyl alcohol on a shop towel, thoroughly clean the hood where the caution label will attach.

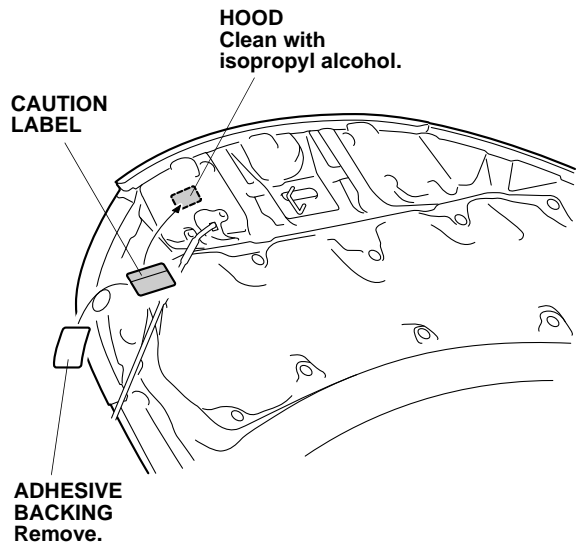

99. Remove the adhesive backing from the caution label, and attach the caution label to the hood in the area shown.

100. Check that all wire harness and cables are routed properly and that all connectors are plugged in.
101. Reinstall all removed parts.
102. Reconnect the negative cable to the battery.
103. Check the operation of the headlights and wipers.
104. Press and hold the radio power button for two seconds to restore the radio and navi (if equipped) system functions.
105. Reset the clock on vehicles without navigation.
106. Proceed to the **REMOTE ENGINE STARTER REGISTRATION** (Page 23) and **FUNCTION CHECK** (Page 26).

REMOTE ENGINE STARTER REGISTRATION

1. Acquire the PCM Code from ISIS.

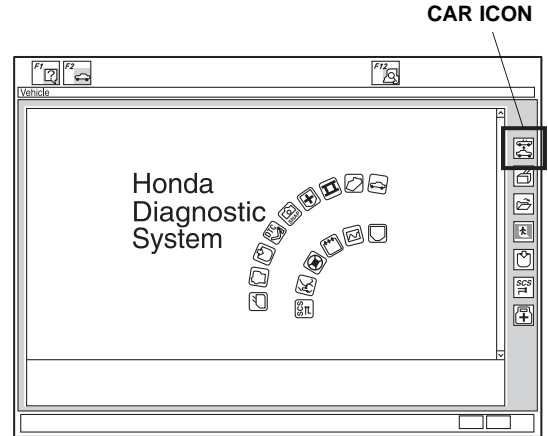

2. Connect the HDS tester to the OBD II data link connector, then turn the ignition switch to the on (II) position.
3. Start the HDS, and click the car icon.
4. Input the VIN and other required information into the HDS, then click the check button.

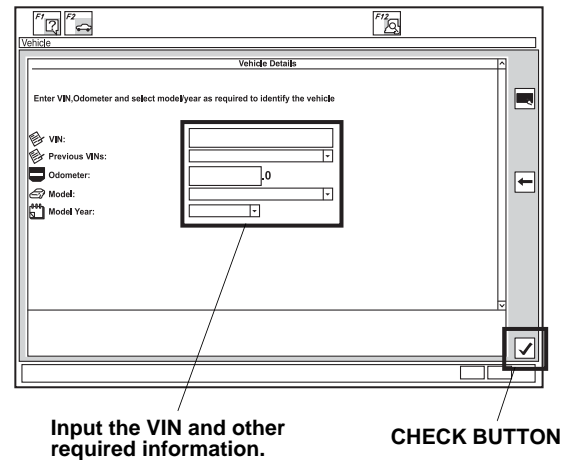

5. Select **Honda Systems**, then click the check button.

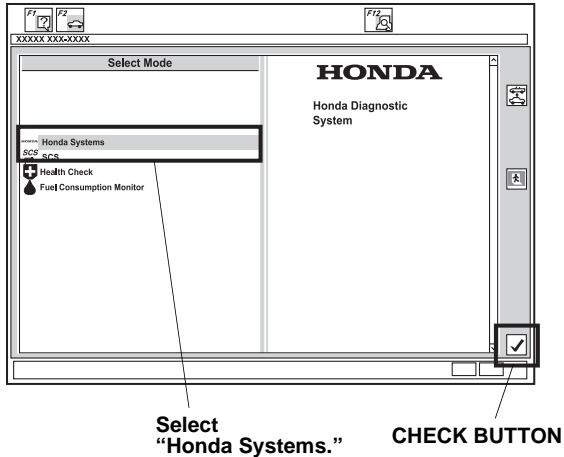

6. Select **R/C ENG STARTER** and click the check button.

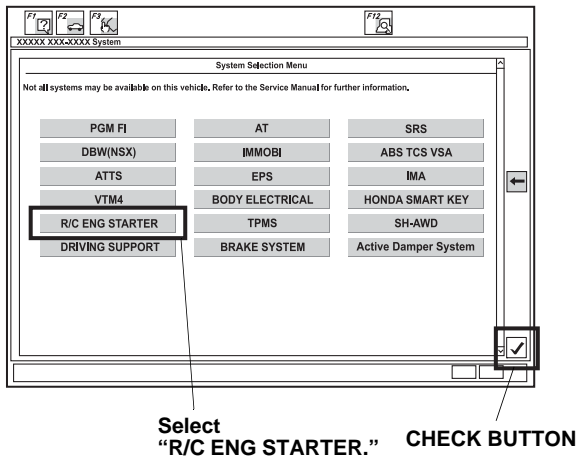

7. Check that **REMARKS** is shown, then click the check button.

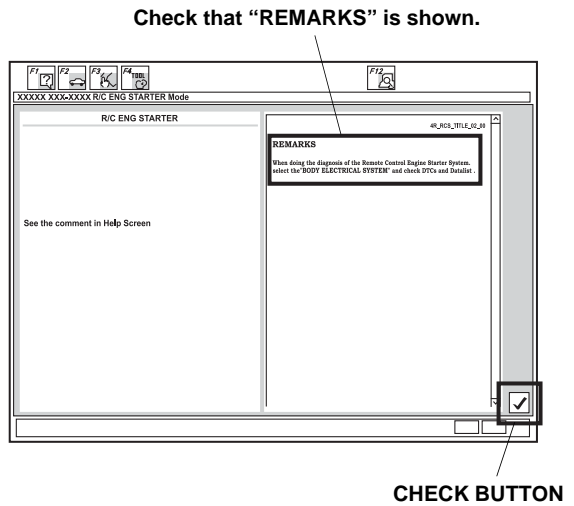

8. Select **REGISTER REMOTE CONTROL ENGINE STARTER UNIT**, then click the check button.

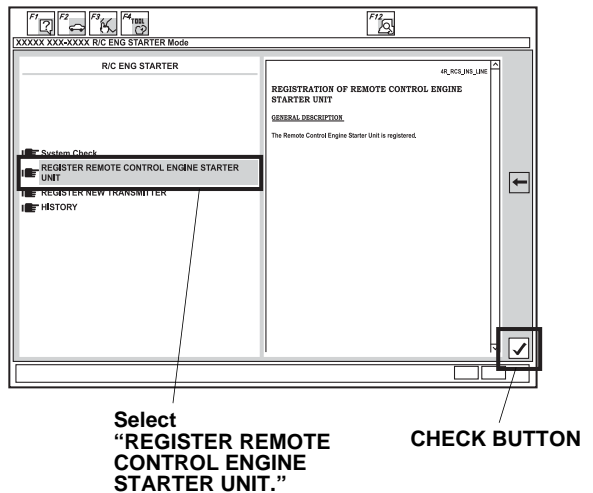

9. The following message will display: **Obtain PCM code (IMMOBILIZER PCM CODE) from iN. This vehicle's VIN will be required to obtain the password (USA).** Click on the check button.

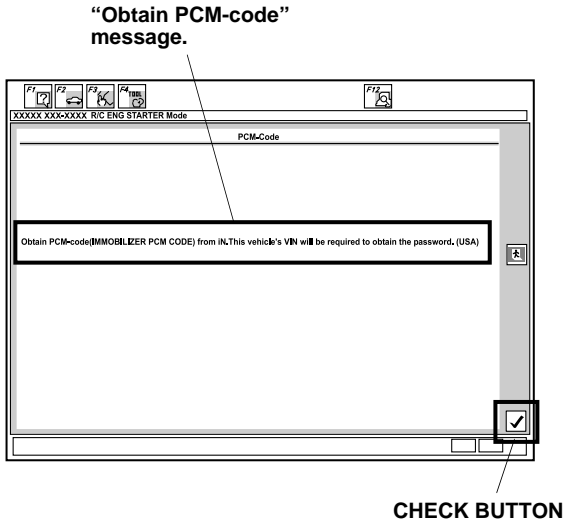

10. Input the PCM Code, then click the check button. NOTE: To ensure security, the PCM code (password) is changed everyday, so it is impossible to register the remote control engine starter if the dates of the PCM code acquisition and registration are different. The date of the HDS tester should also be the same.

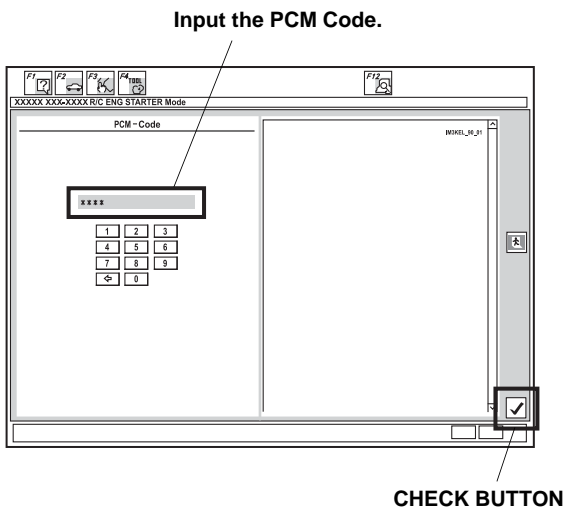

11. The following message will display: **The registration of the Remote Control Engine Starter Unit has been completed.** Click on the check button.

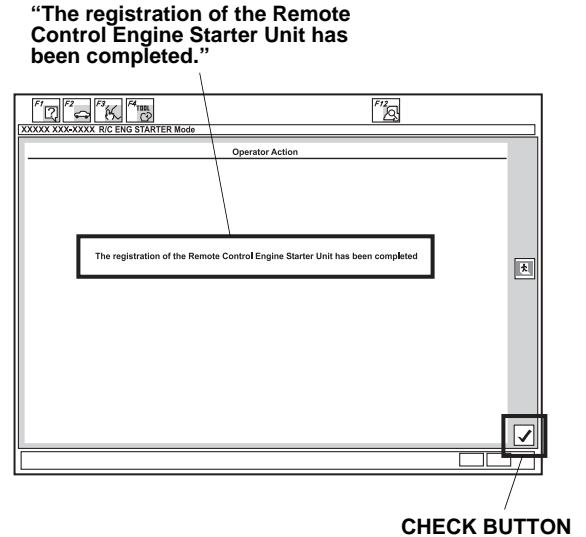

12. The following message will display: **Check that the engine can be started by the Transmitter.** Click on the check button.

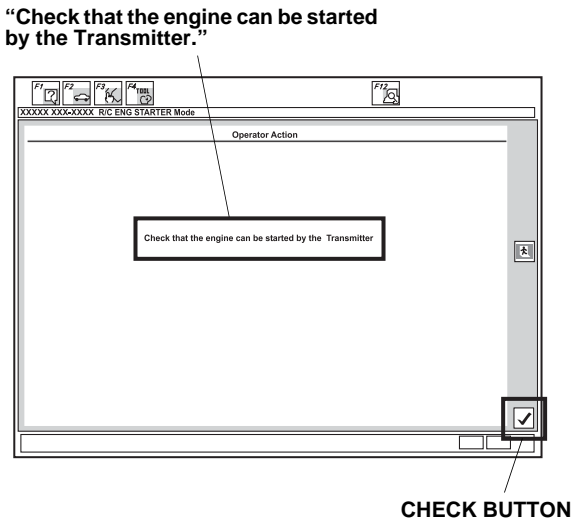

13. Perform the function test on page 26, then disconnect the HDS.

FUNCTION CHECK

Operating Conditions

- The hood is closed
- The shift lever is in park
- The key is out of the ignition and the key is outside the vehicle
- All doors and tailgate closed and locked

Inspection

1. Press the command button, and then, within 1 second, press the start button on the transmitter.
The engine should start if all operating conditions are met.

Does the engine start?

Yes - Operation is normal.
No: <ul style="list-style-type: none">• Make sure all "Operating Conditions" are met.• Check the engine starter harness connections.• Connect the HDS and check for an indicated failure. (Refer to the appropriate service manual for details.)

2. Press the command button on the transmitter and, within 1 second, press the stop button. The engine should stop.

Does the engine stop?

Yes - Operation is normal.
No - Check the engine starter harness connections.

3. After the engine has stopped, start the engine again, and check that the engine stops after each of the following conditions:

NOTE: After each test the ignition key must be cycled, or the driver's door must be opened and closed.

- Move the shift lever out of the P position.
- Unlock or open the doors or the tailgate.
- Open the hood.
- Insert the key in the ignition.
- Press on the brake pedal.

Does the engine stop after each of these tests?

Yes - Operation is normal.
No - Check the engine starter harness connections.

4. Check that the power windows and the moonroof do not function when the engine is started with the transmitter.
5. Start the engine again, press the command button on the transmitter two times and check the vehicle condition on the display.
6. Check the operation of the transmitter when the vehicle is 100 m to 150 m (325 to 490 ft.) away and in direct sight.
7. Insert the key in the ignition and start the engine, check the operation of the headlights and wipers.

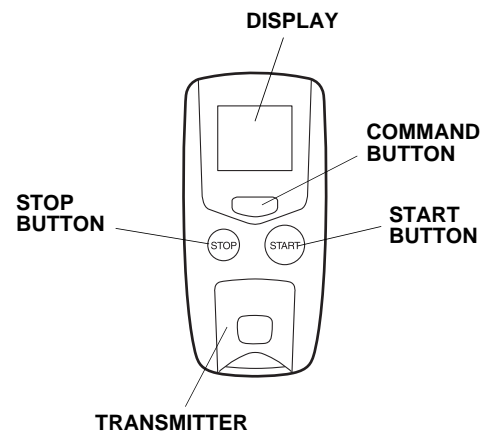

How to Program an Additional Transmitter

1. Connect the HDS to the data link connector.
2. Start the HDS and click on the car icon.
3. Input the vehicle's VIN and other required information.
4. Select **Honda Systems**.
5. Select **R/C ENG STARTER**.
6. Select **REGISTER NEW TRANSMITTER**.
7. When "Ready to program the new transmitter" shows, select **ENTER**.
8. Press and release the Command button.
9. Press and release the Stop button.
10. Perform the function check on both transmitters.

NOTE: Only 2 remotes can be stored in the system's memory.