



INSTALLATION INSTRUCTIONS

Accessory
REMOTE ENGINE STARTER

Application
**2011 FIT
(SPORT MODEL)**

Publications No.
All 45115
Issue Date
NOV 2010

PARTS LIST

Remote Engine Starter Unit Kit P/N 08E91-E22-101B

Transmitter

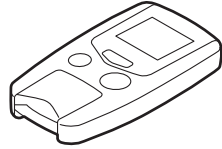

Control unit

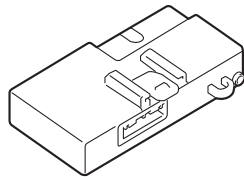

Antenna

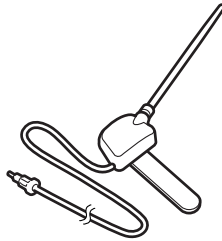

Key ring



Protective tape (black)



Caution label



Fuse label

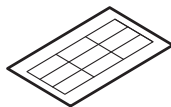

Accessory User's Information Manual

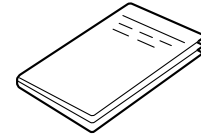

Quick Start Guide

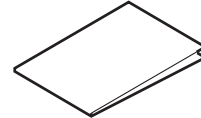

Remote Engine Starter Attachment Kit P/N 08E92-TK6-100A

Engine starter harness

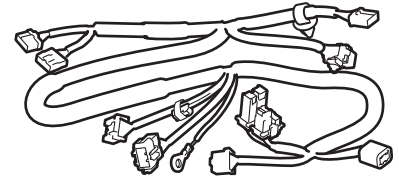

Control unit bracket

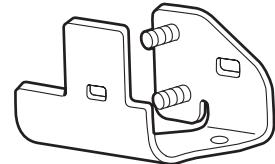

Relay bracket

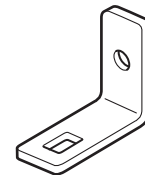

3 Relays

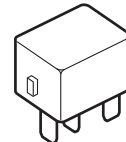

Ground bolt



Template

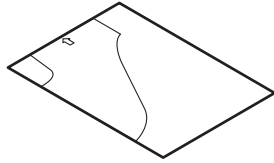

20 Wire ties

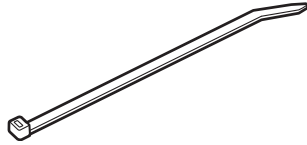

3 Urethane tapes

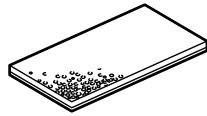

2 Flange nuts



A-Pillar clip



TOOLS AND SUPPLIES REQUIRED

- Phillips screwdriver
- Flat-tip screwdriver
- Small flat-tip screwdriver
- Ratchet
- 10 mm Socket
- 10 mm Combination wrench
- Diagonal cutters
- Isopropyl alcohol
- Shop towel
- Scale
- Scissors
- HDS (Honda Diagnostic System)
- Felt-tip pen
- Masking tape
- Needle nose pliers

Illustration of the Engine Starter Installed on the Vehicle

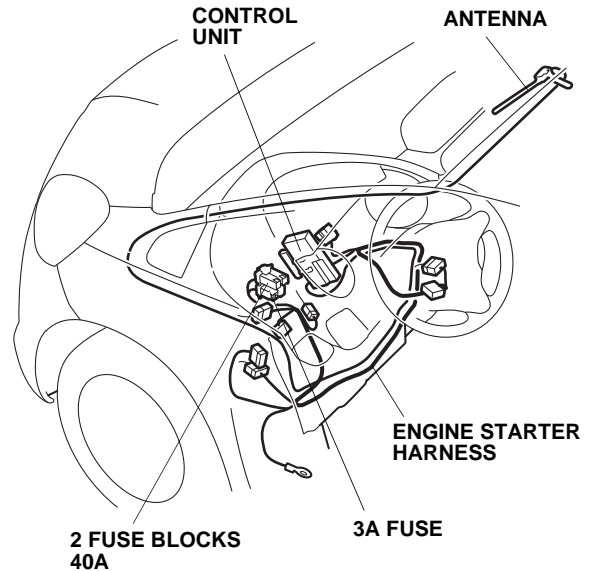

INSTALLATION

Customer Information: The information in this installation instruction is intended for use only by skilled technicians who have the proper tools, equipment, and training to correctly and safely add equipment to your vehicle. These procedures should not be attempted by “do-it-yourselfers.”

NOTE: This antenna should be installed only if the ambient air temperature 15°C (60°F) or above.

1. Make sure you have the anti-theft code for the audio unit and navigation system (if equipped), then write down the radio station presets.
2. Disconnect the negative cable from the battery.

Setting the Control Unit

3. Get the control unit. Using a small flat-tip screwdriver, adjust the switches to the settings shown.

NOTE:

- The switches must be set before the control unit is plugged in.
- If the switch settings are not correct, the engine starter will not operate properly.
- If you are setting the switches with the control unit installed in the vehicle, touch a metal part of the screwdriver to any metal part of the vehicle to discharge any static electricity.
- If you change the switch settings with the unit connected, you must disconnect the unit, then reconnect it before the new settings are recognized.

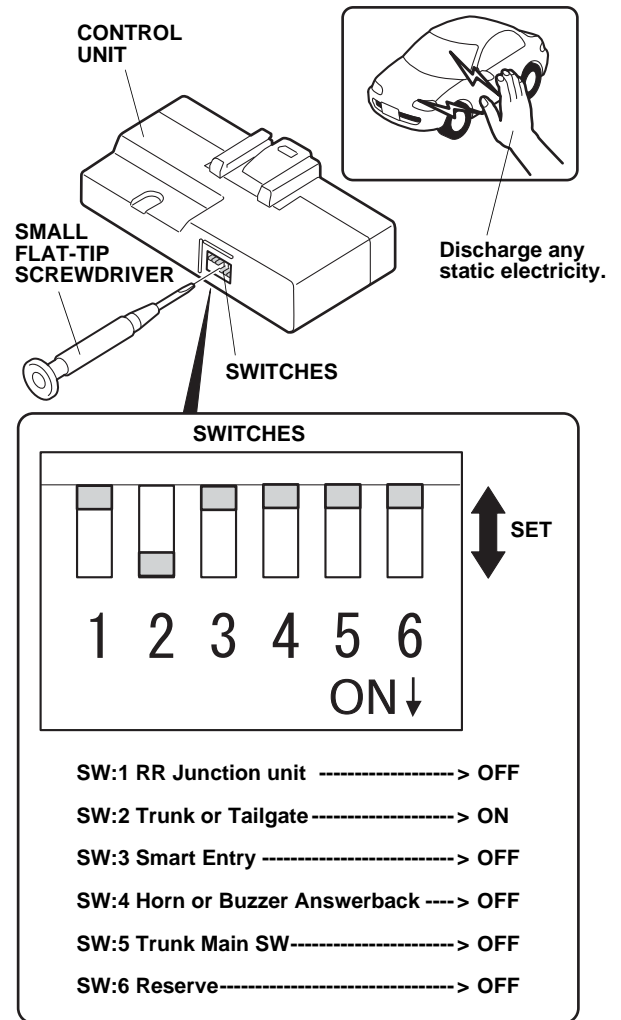

- Using isopropyl alcohol on a shop towel, clean the area where the protective tape will attach. Remove the adhesive backing, and attach the protective tape to the control unit over the switches.

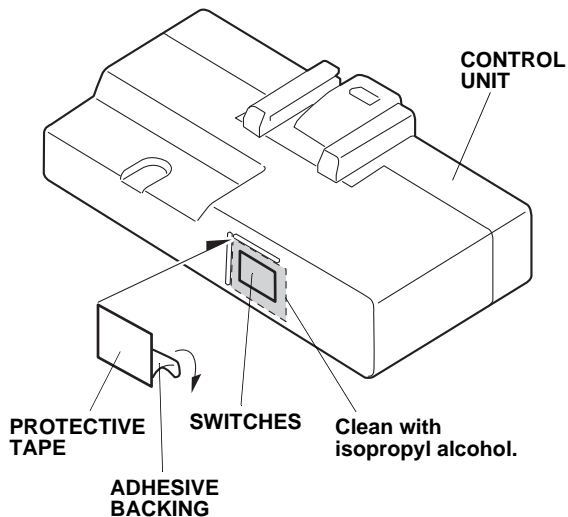

Removing the Vehicle Parts

- Remove the driver's sunvisor.
 - Pivot down the left sunvisor.
 - Locate the slot in the sunvisor holder, and insert a flat-tip screwdriver into the slot. Push in and hold the retaining tab.
 - While holding the retaining tab, push up on the left sunvisor and rotate it toward the door to remove.

NOTE: If the retaining tab did not stay pushed in, return the left sunvisor to its original position and repeat the steps above.

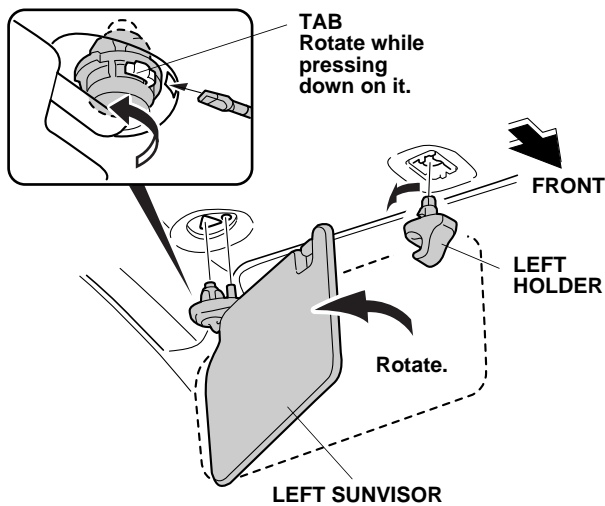

- Turn the left sunvisor holder 90°, then remove it.

- Using a small flat-tip screwdriver wrapped with a shop towel, pry out and remove the left and right lenses (four retaining tabs each).

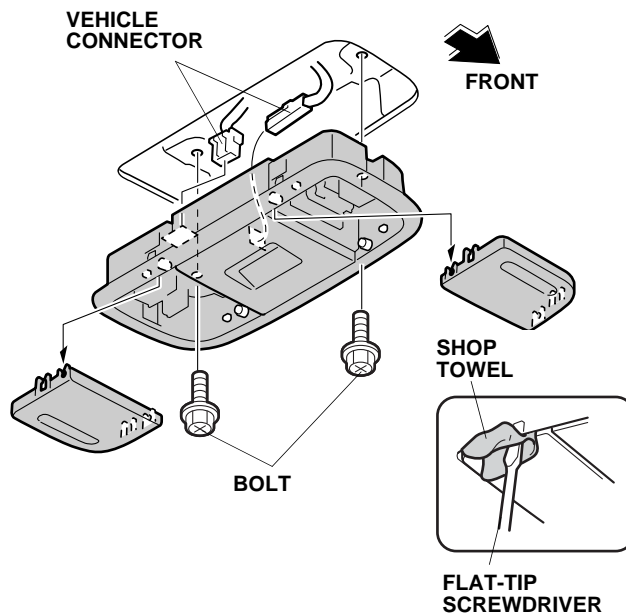

- Remove the map light (two bolts and disconnect the two vehicle connectors).
- Remove the left A-pillar trim:
 - Pull away the door seal around the A-pillar trim.
 - Using your fist, tap the left A-pillar at the area marked "SIDE CURTAIN AIRBAG" to release the clip.
 - Pull the left A-pillar out towards you and disengage the pin from the clip.

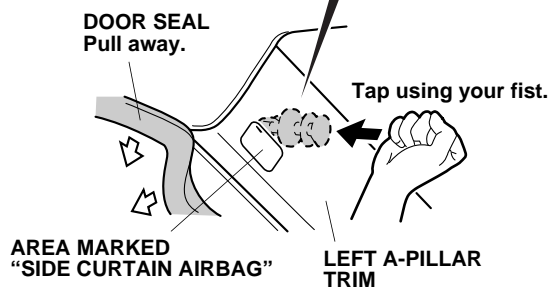
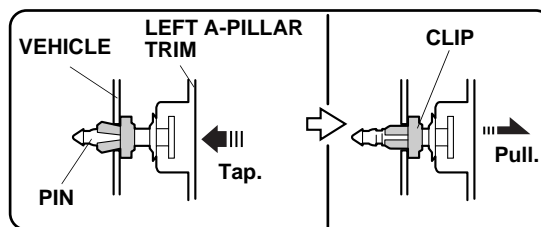

- Remove the left A-pillar trim (two clips).

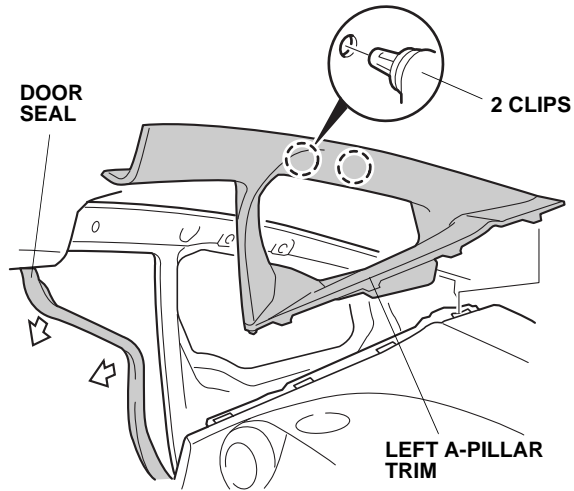

- Remove and discard the clip from the left A-pillar trim, and install a new A-pillar clip.

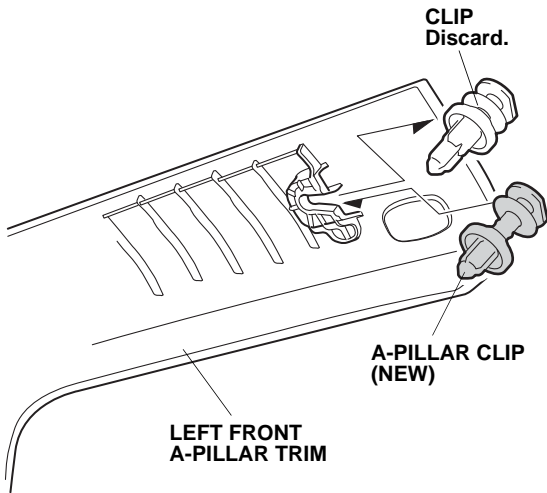

- Turn the knob on the driver's dashboard under cover counterclockwise. Remove the driver's dashboard under cover (one clip and two labels).

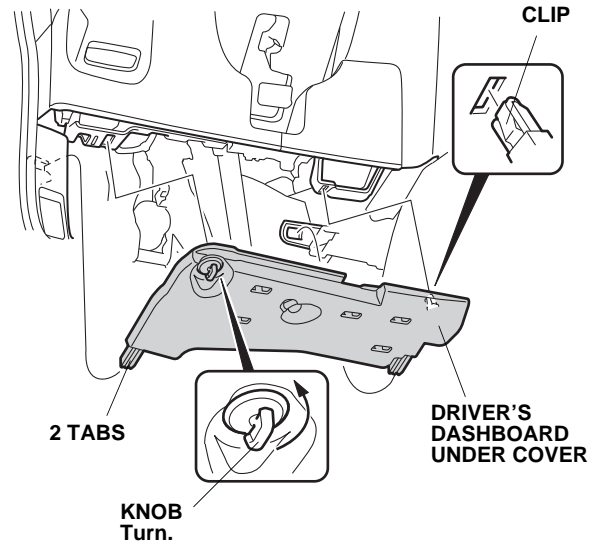

- Remove the fuse access panel (two clips, five tabs, and two hooks).

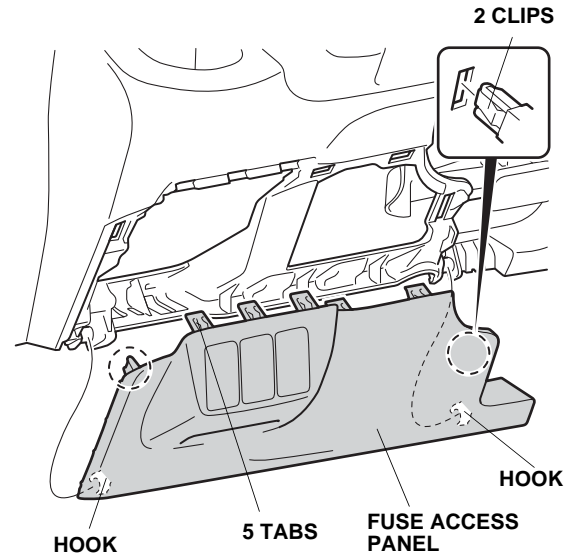

- Remove the driver's dashboard side cover (three tabs and three hooks).

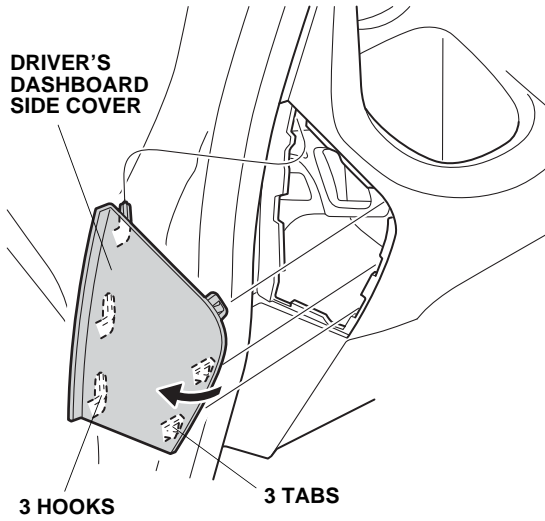

- Remove the driver's dashboard lower cover (three clips and two tabs).

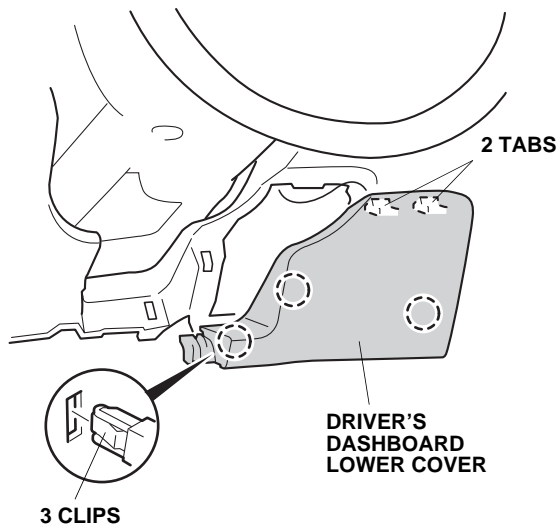

- Pull away the door seal around the driver's kick panel.

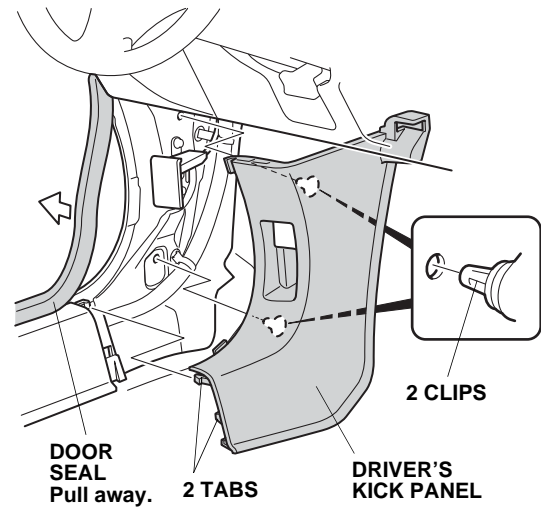

- Remove the driver's kick panel (two clips and two tabs).

- Insert a long blade flat-tip screwdriver along the guide of the steering column lower cover, and release the retaining tab on the column upper cover.

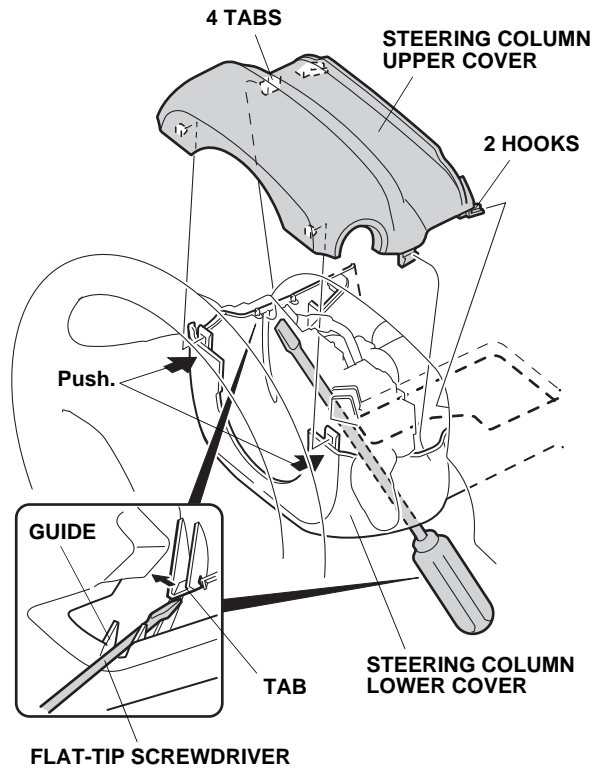

- Remove the steering column upper cover (four tabs and two hooks).

19. Lower the tilt lever. Remove the steering column lower cover (three self-tapping screws).

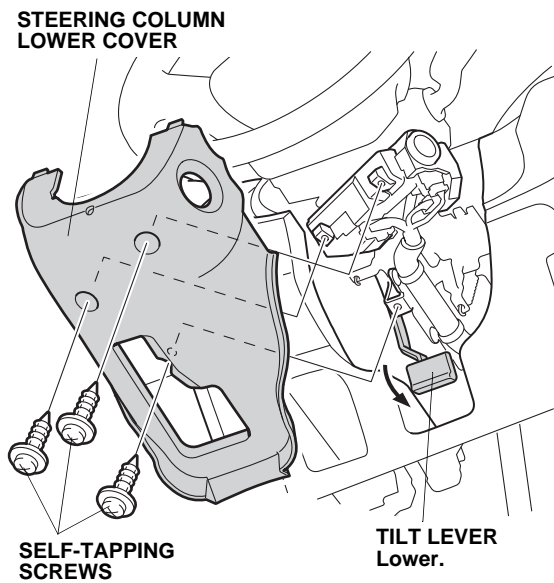

20. Remove the two mounting bolts from the fuse box.

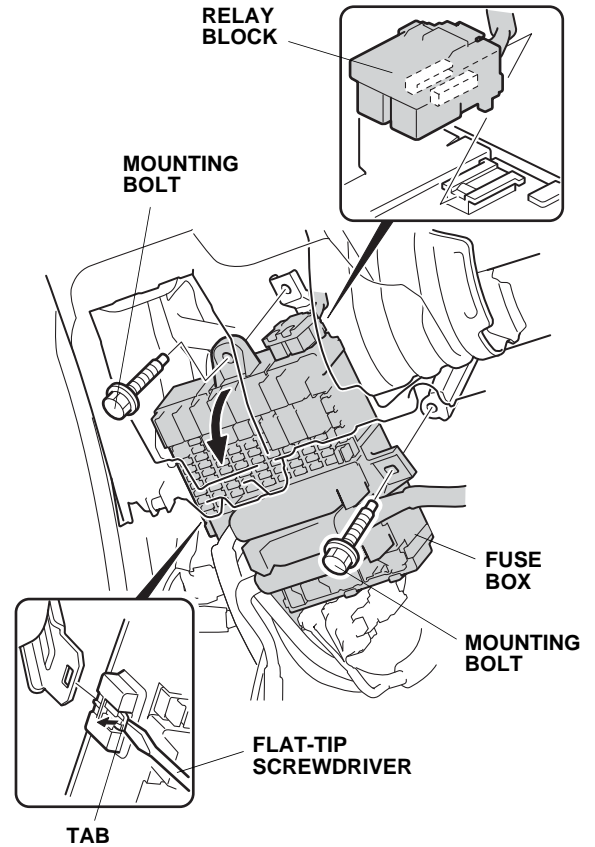

21. Using a flat-tip screwdriver, release the relay block tab. Slide the relay block toward you and remove it from the top of the fuse box.
22. Using a flat-tip screwdriver, release the side tab, and tilt the fuse box toward you.

Routing the Engine Starter Harness

23. Attach the two 40A fuse labels and the 3A fuse label to the engine starter harness fuse block.

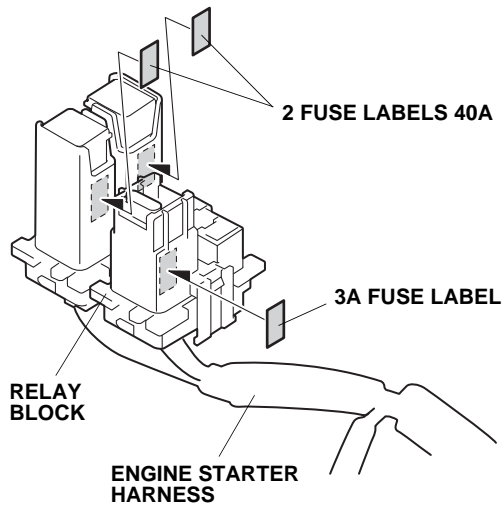

24. Install the three relays to the engine starter harness relay blocks.

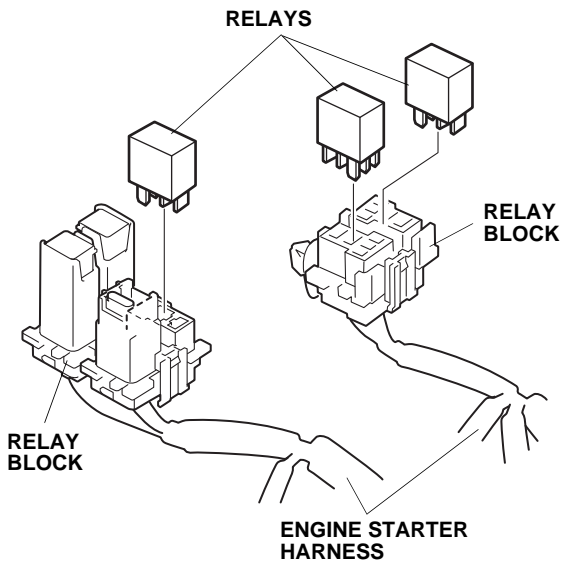

25. Unplug the vehicle 10-pin connector (green) from the back of the fuse box.

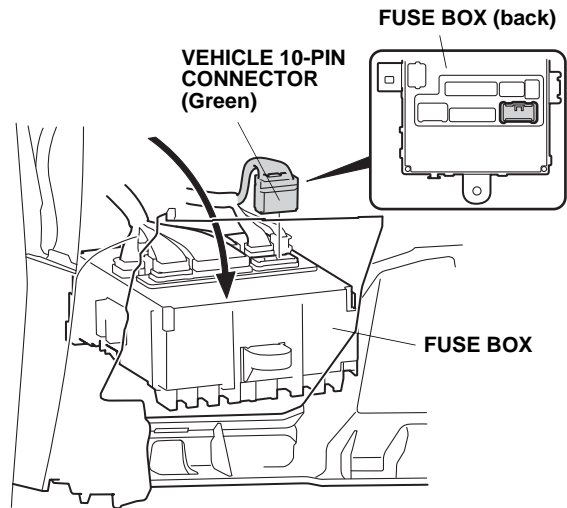

26. Unplug the vehicle 16-pin connector from the fuse box, and plug the engine starter harness 16-pin connectors into the vehicle 16-pin connector and the fuse box, as shown.

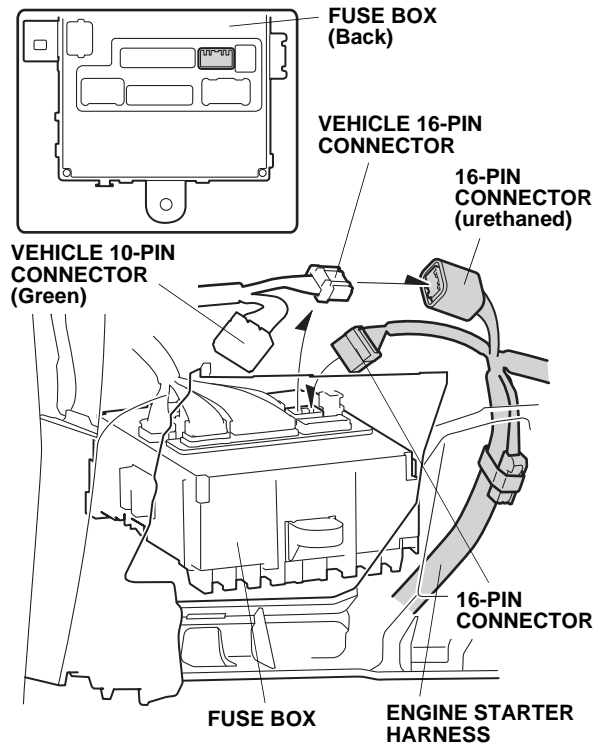

27. Reconnect the vehicle 10-pin connector (green) into the back of the fuse box.
28. Reinstall the fuse box using the two mounting bolts. Reconnect the relay block to the top of the fuse box.

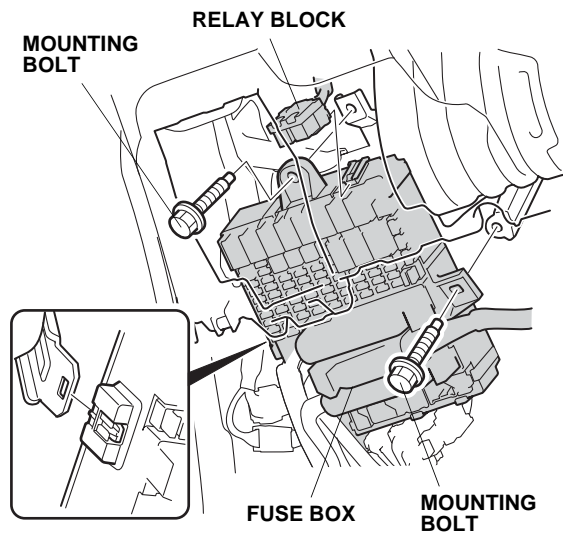

29. Remove the nut from the vehicle bracket.

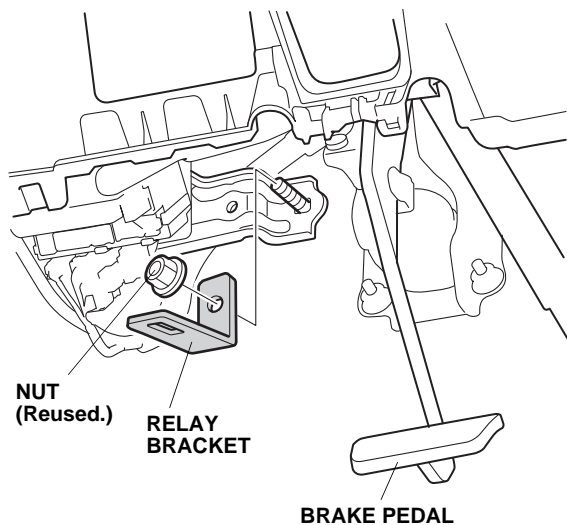

30. Secure the relay bracket to the vehicle with the nut you removed.

31. Secure the clip near the relay block of the engine starter harness to the square hole in the relay bracket you just installed.

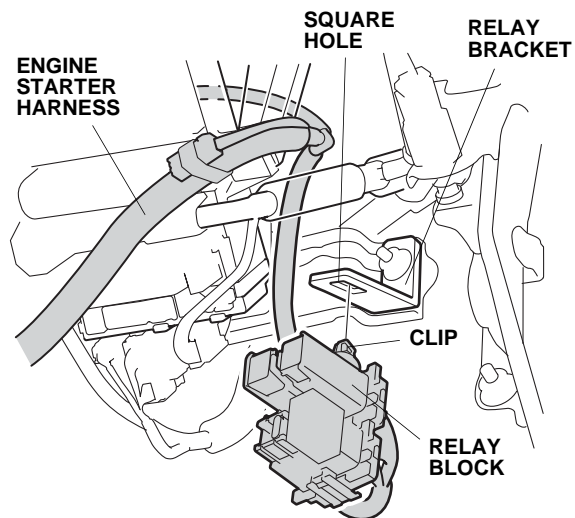

32. Secure the engine starter harness to the vehicle harness using one wire tie.

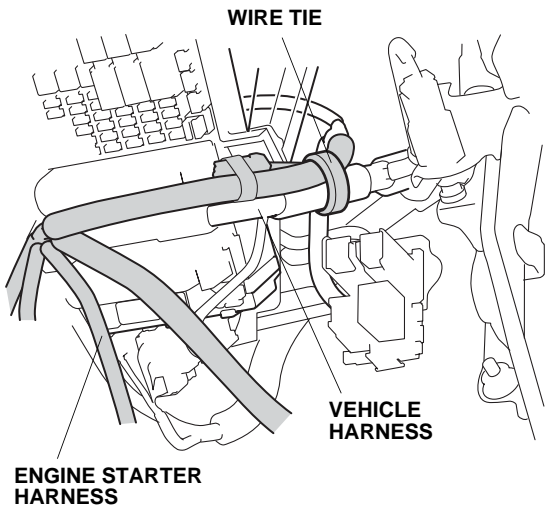

33. Loosely secure the engine starter harness (at the green tape) to the vehicle frame using one wire tie. If another accessory is already installed, secure the engine starter harness to the other accessory harness.

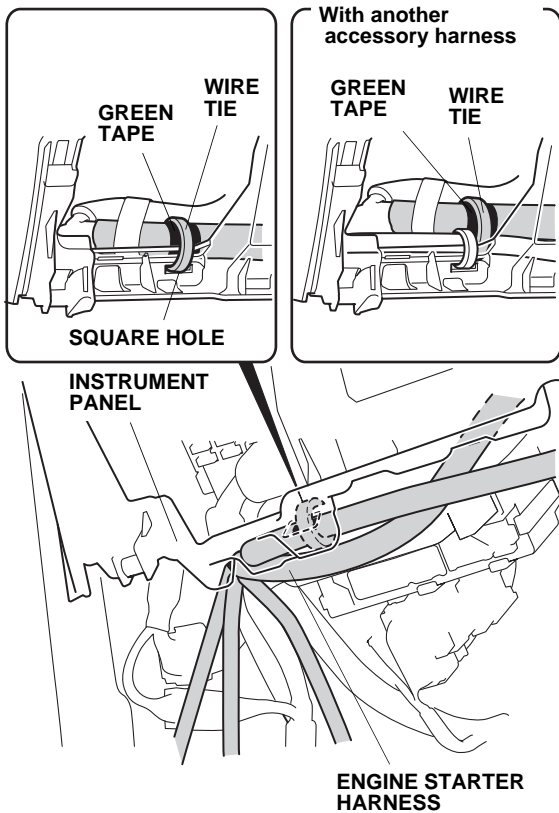

34. Unclip the 4-pin connector (if equipped) from the vehicle 13-pin connector, and then remove the 13-pin connector from the connector holder on the bottom of the fuse box.

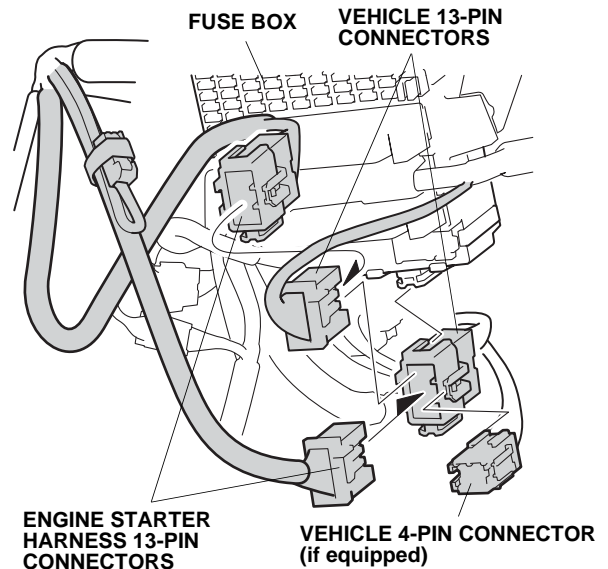

35. Unplug the 13-pin connectors, and plug the engine starter harness 13-pin connectors into them.
36. Attach the engine starter harness to the bottom of the fuse box, and attach the vehicle harness 13-pin connector to the engine starter harness 13-pin connector. If equipped, attach the 4-pin connector to the side of the engine starter harness 13-pin connector.

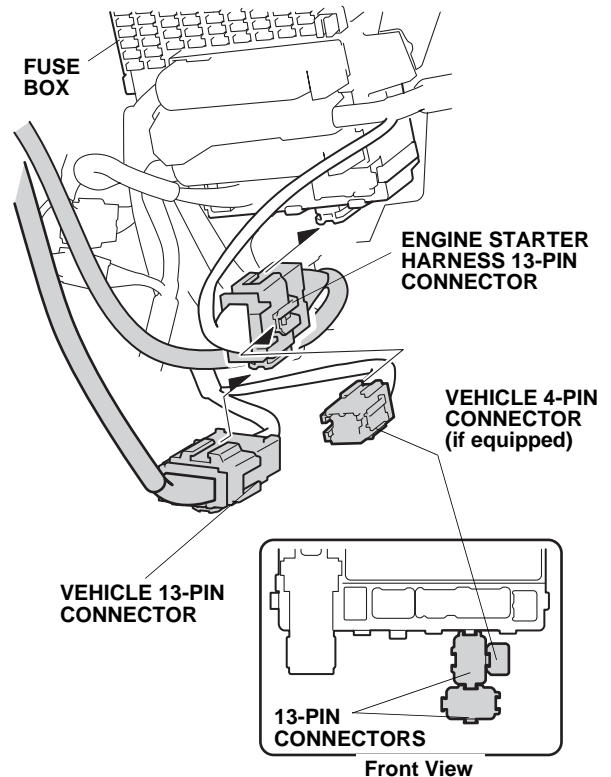

37. Remove the top bolt from the hood release lever. Attach the engine starter harness ground terminal with the supplied ground bolt.

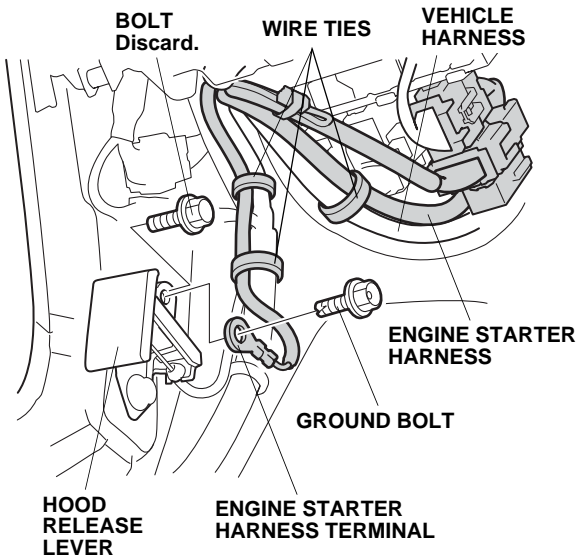

38. Using three wire ties, secure the engine starter harness to the vehicle harness.
39. Route the engine starter harness along the bottom panel toward the center console, and then back under the dashboard. Loosely attach the engine starter harness to the vehicle frame and to the vehicle harness (at each green tape) using two wire ties.

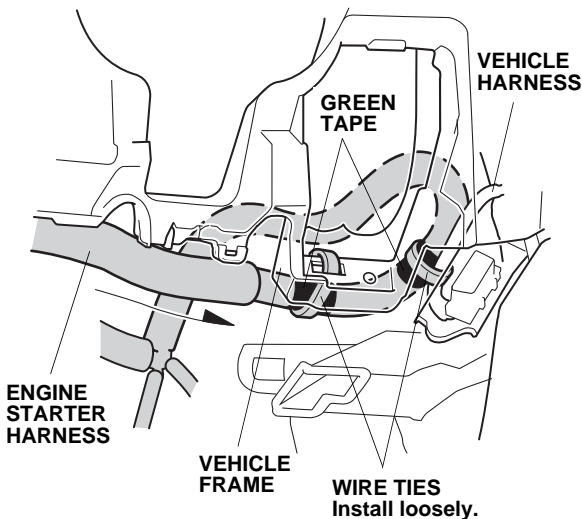

40. Just to the right of the steering shaft, locate the steering column support bracket. Attach the control unit bracket to the support bracket using two flange nuts.

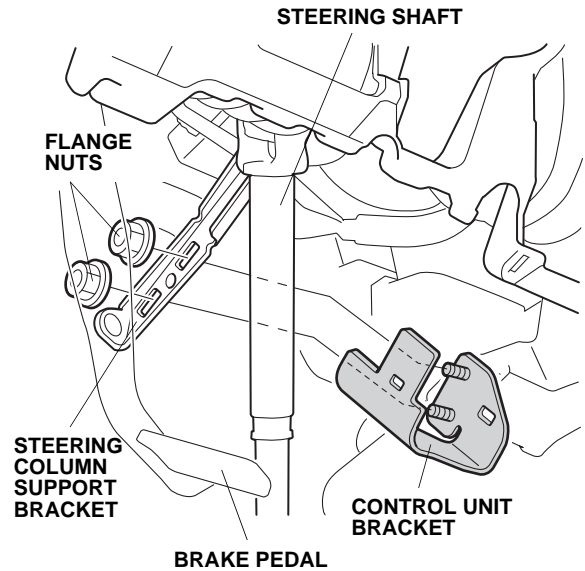

41. Attach the clip on the relay block of the engine starter harness to the square hole in the control unit bracket.

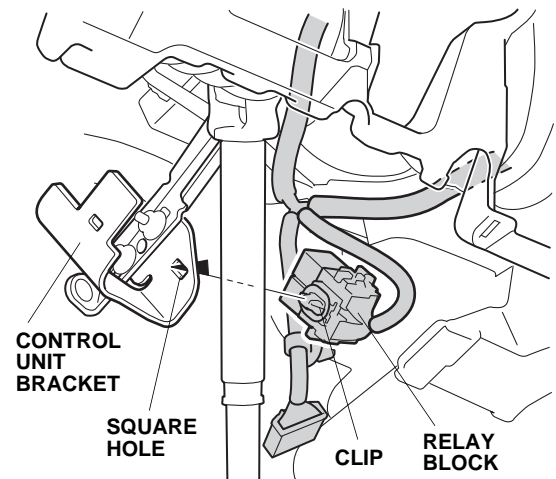

42. Plug the engine starter harness 28-pin connector into the control unit, and mount the control unit to the control unit bracket.

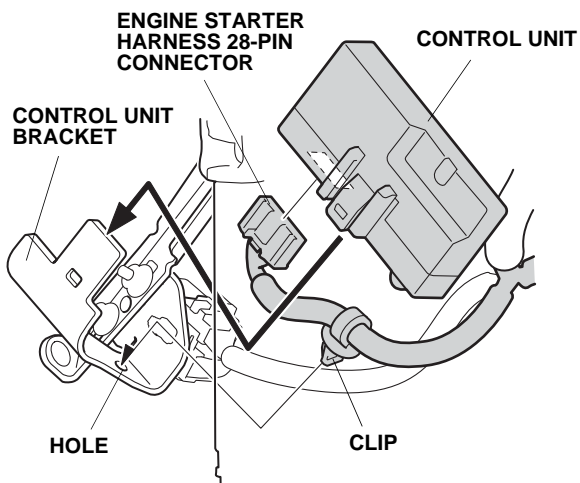

43. Secure the clip on the 28-pin connector of the engine starter harness to the hole in the control unit bracket.
44. Align the green tape on the engine starter harness with the vehicle clip, and secure it to the vehicle harness using one wire tie.

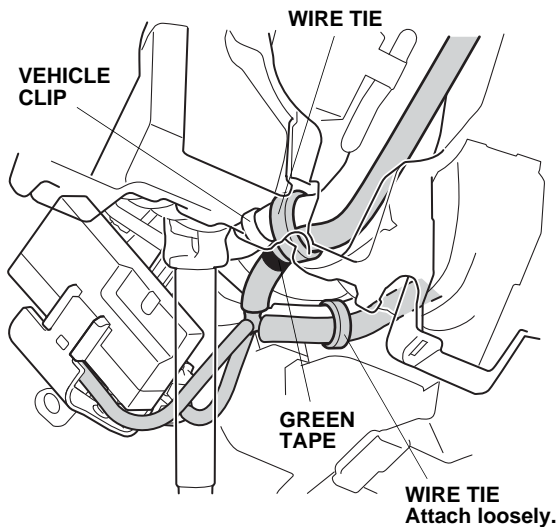

45. Loosely attach the engine starter harness to the vehicle harness using one wire tie.

46. Unplug the vehicle harness 6-pin connectors below the ignition switch, and plug the engine starter harness 6-pin connectors into them.

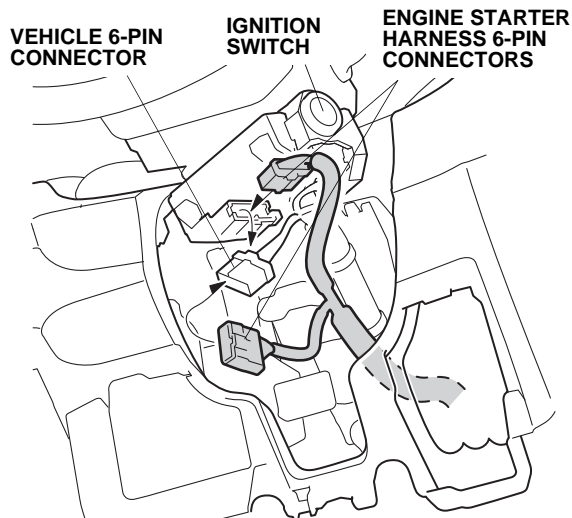

47. Align the green tape on the engine starter harness with the vehicle clip, and secure it to the vehicle harness using two wire ties.

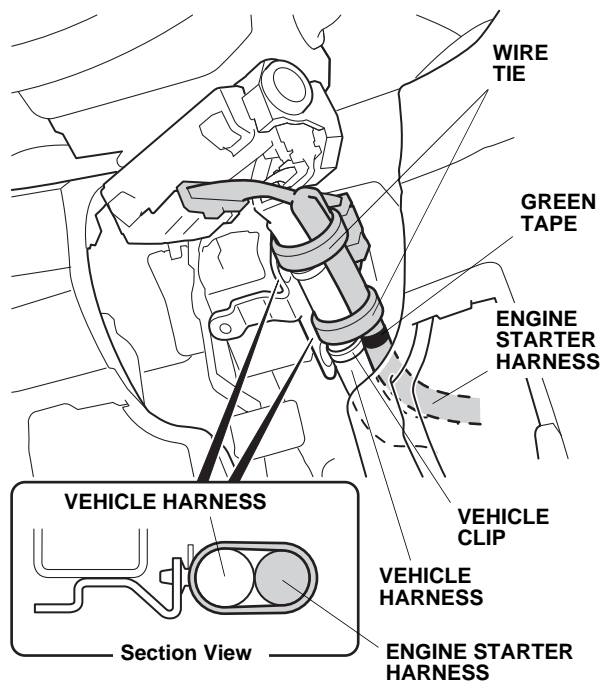

Antenna Installation

48. Using scissors, cut out the template.

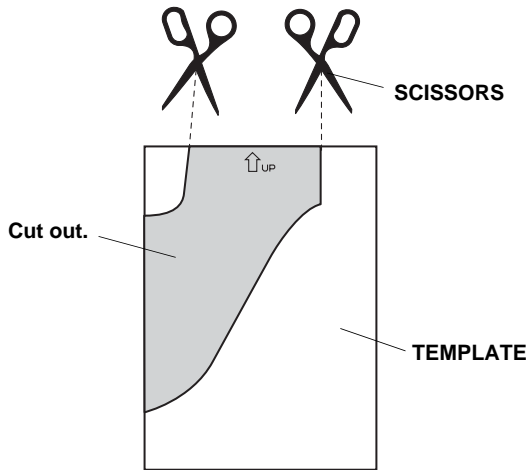

49. Using scissors, cut two urethane tapes in half. Wrap the four cut pieces of urethane tape around the antenna cable at the measurements shown.

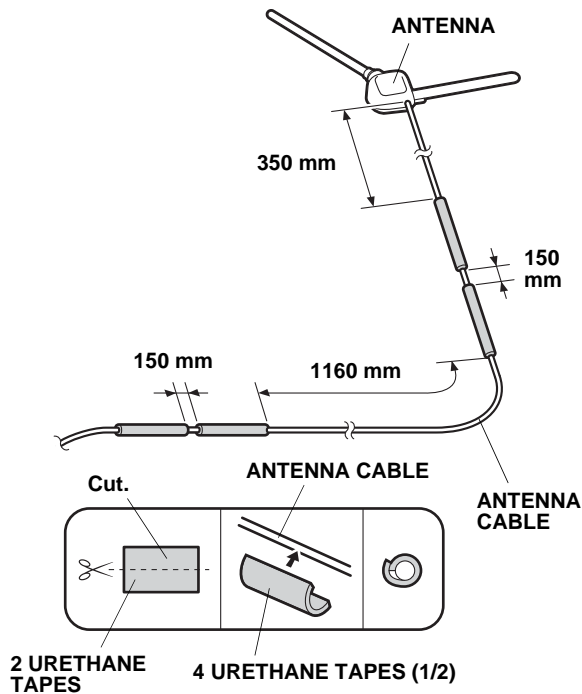

50. Using two pairs of needle nose pliers, bend the antenna plate according to the dimensions shown.

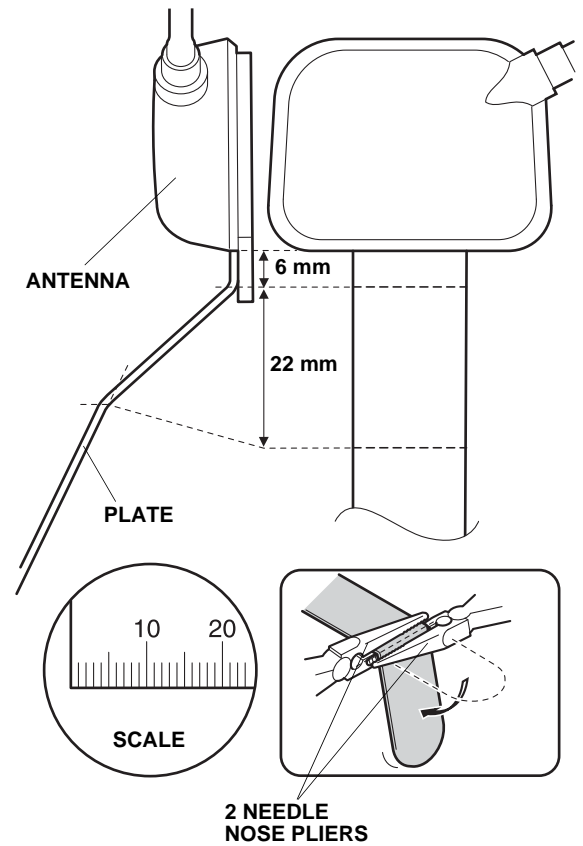

51. Attach the template to the windshield with masking tape as shown.

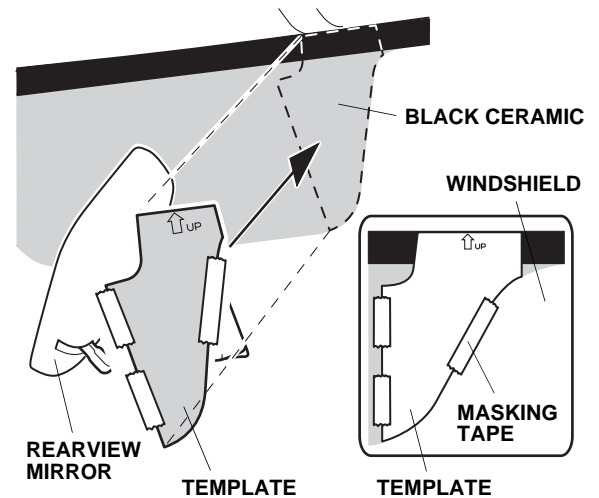

52. Using isopropyl alcohol on a shop towel, clean the windshield where the antenna will attach.

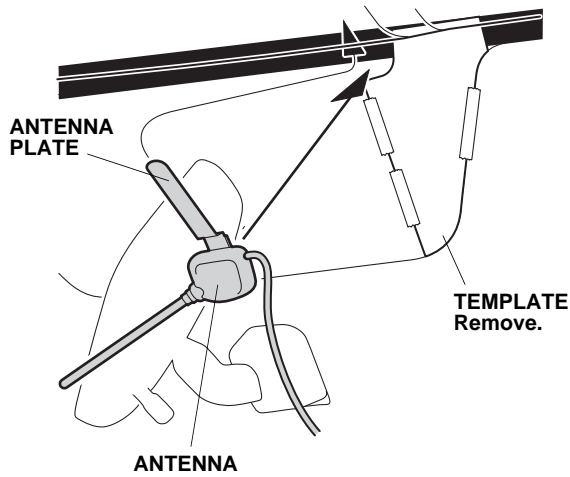

53. Remove the adhesive backing from the antenna. Insert the antenna plate under the headliner, align the antenna with the template, and attach the antenna to the windshield. Remove the template.
54. Gently pull down the headliner, and tuck the antenna cable under it. Be careful not to crease the headliner.

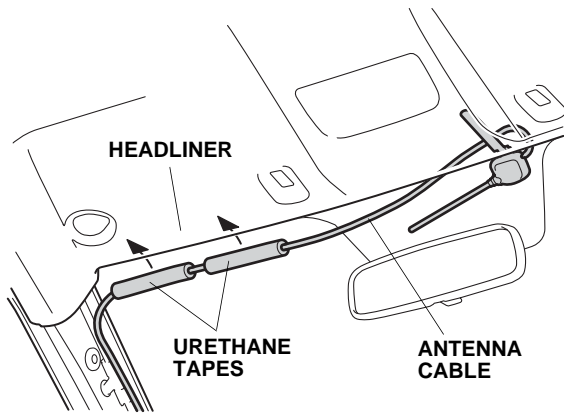

55. Using isopropyl alcohol on a shop towel, clean the roof panel where the urethane tape will attach.

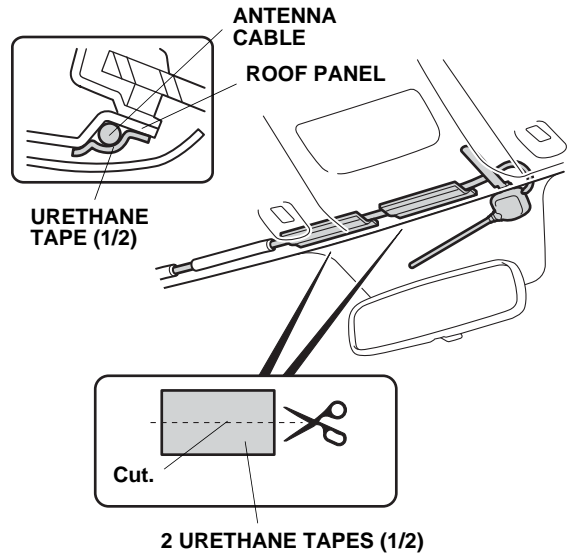

56. Using scissors, cut one urethane tape in half. Route the antenna cable towards the driver's side of the vehicle, and secure the antenna cable to the roof panel with the two cut pieces of urethane tape.
57. Along the A-pillar, secure the antenna cable to the vehicle harness using five wire ties.

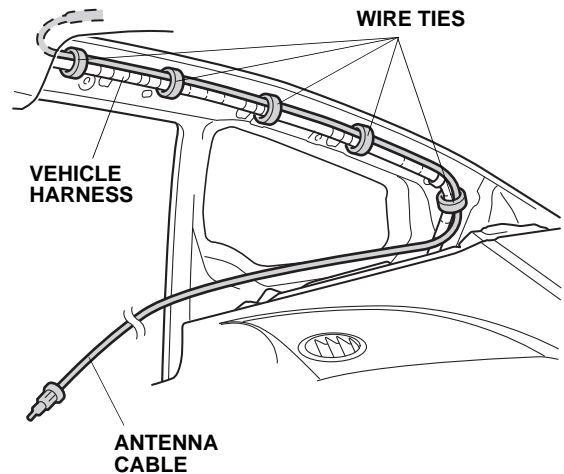

58. Secure the antenna cable to the vehicle frame using three wire ties.

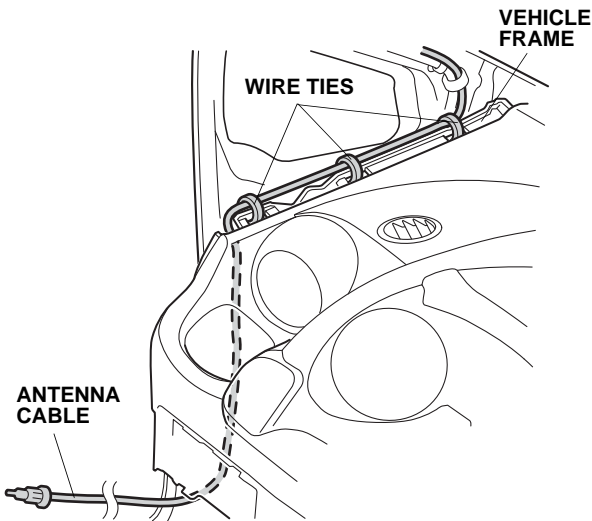

59. Route the antenna cable through the wire tie loosely installed in step 33, and toward the center console.

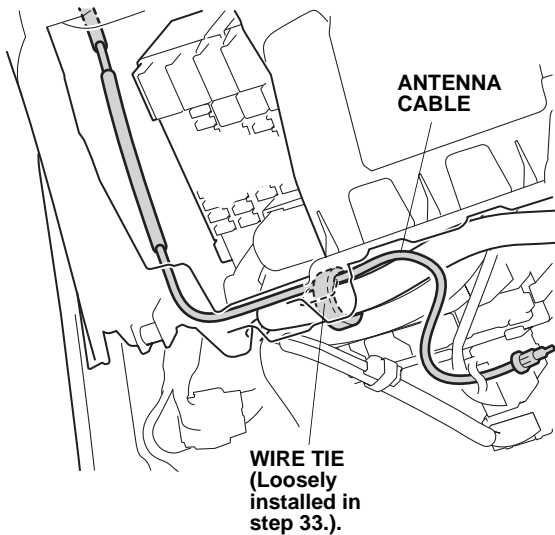

60. Route the antenna cable through the two wire ties loosely installed in step 39, toward the control unit.

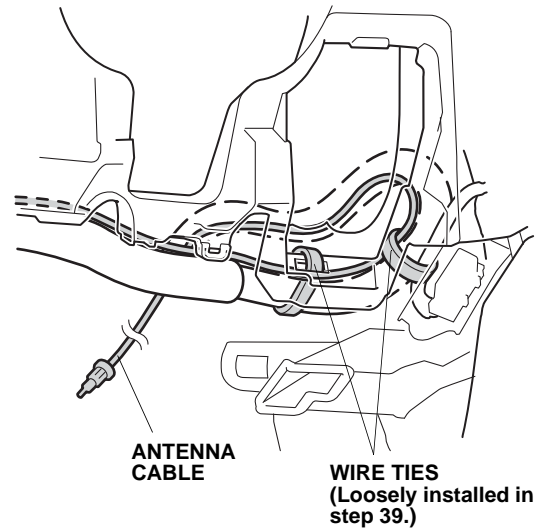

61. Continue routing the antenna cable through the wire tie (loosely installed in step 45), and plug the antenna cable connector into the control unit.

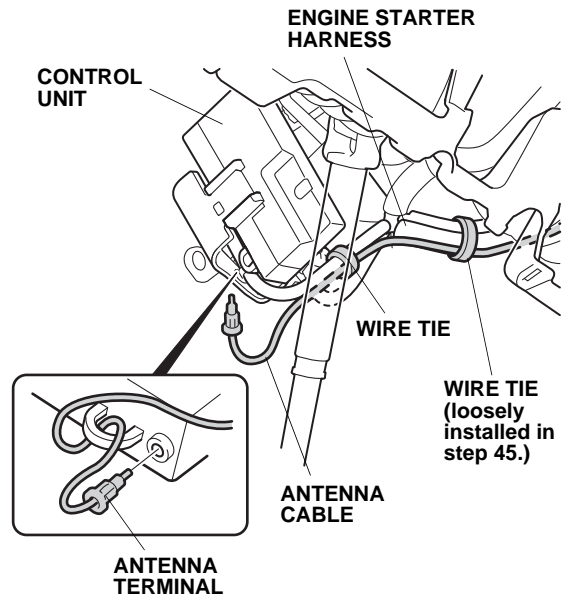

62. Secure the antenna cable to the engine starter harness using one wire tie.
63. Tighten all of the wire ties that were loosely installed.

64. Under the hood, locate the area on the hood where the caution label will attach, and clean the area using isopropyl alcohol on a shop towel.

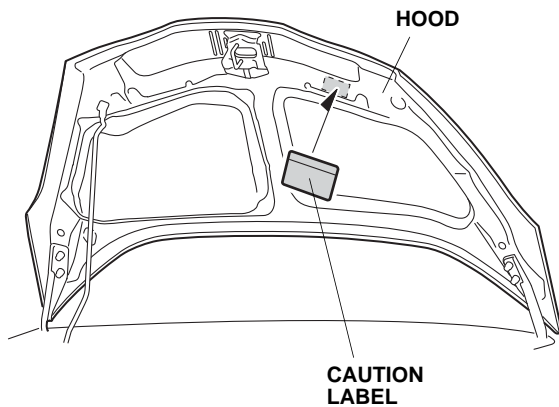

65. Attach the caution label to the hood in the area shown.
66. Check that all wire harnesses and cables are routed properly and that all connectors are plugged in.
67. Reinstall all removed parts. Take care not to pinch the side curtain airbag with the clip during reinstallation of the left A-pillar trim. Do not push excessively on the A-pillar trim.
68. Reconnect the negative cable to the battery. Check the operation of all electrical items, including any accessories.
69. Enter the customer's audio unit anti-theft code and navigation system (if equipped), and reset the radio station presets.
70. Reset the clock on models without navigation.
71. Do the REMOTE ENGINE STARTER REGISTRATION and FUNCTION CHECK (on pages 17-20).

REMOTE ENGINE STARTER REGISTRATION

1. Acquire the PCM code from ISIS.
2. Connect the HDS tester to the OBD II data link connector, then turn the ignition switch to ON (II).
3. Start the HDS, and click the car icon.

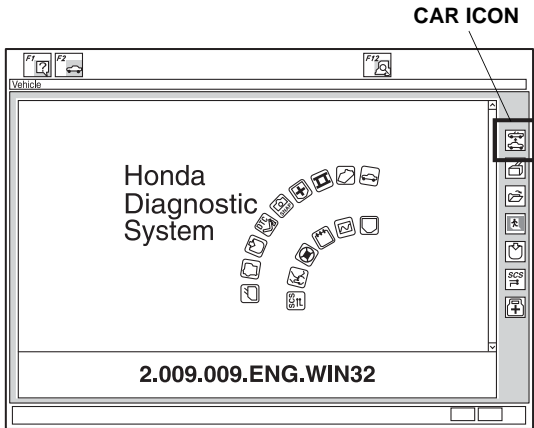

4. Input the VIN and other required information into the HDS, then click the check button.

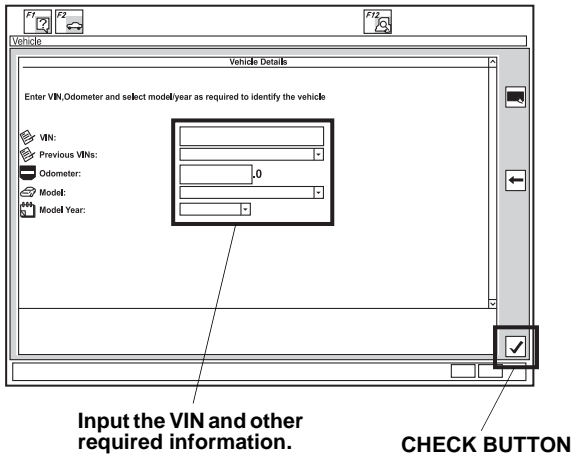

5. Select **Honda Systems**, then click the check button.

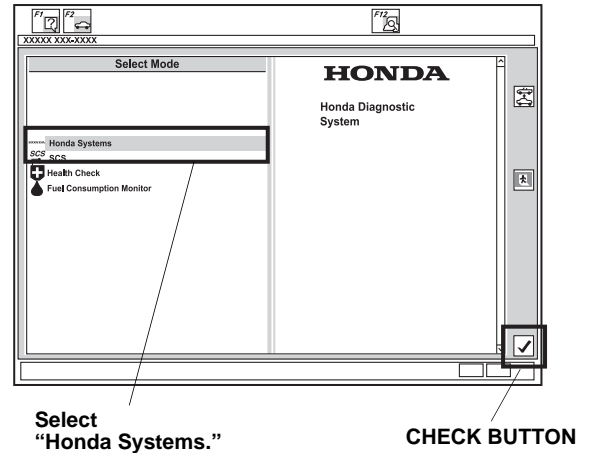

6. Select **R/C ENG STARTER** and click the check button.

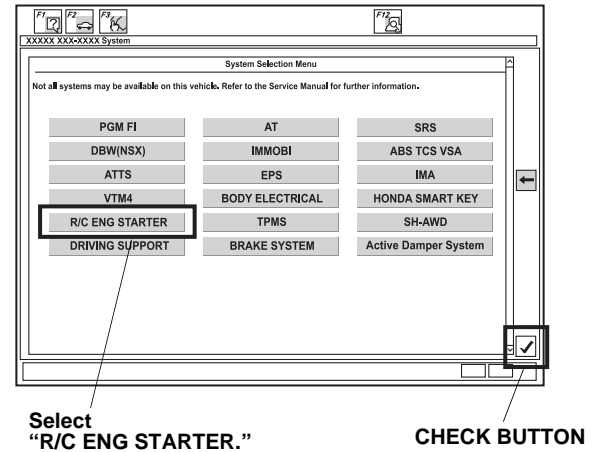

7. A **REMARKS** message will display. Click the check button.

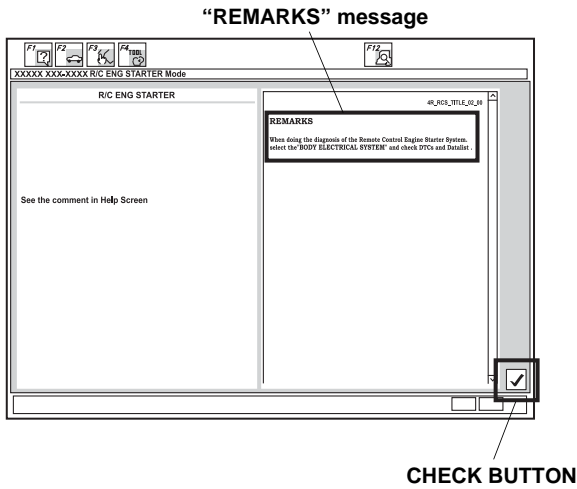

8. Select **REGISTER REMOTE CONTROL ENGINE STARTER UNIT**, then click the check button.

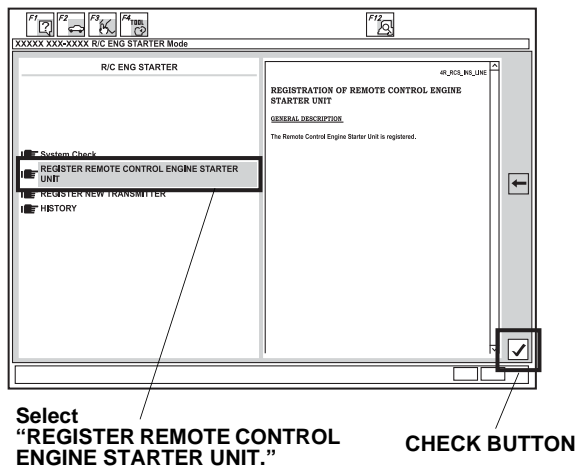

9. The following message will display: **Obtain PCM-code (IMMOBILIZER PCM CODE) from iN. This vehicle's VIN will be required to obtain the password. (USA).** Click the check button.

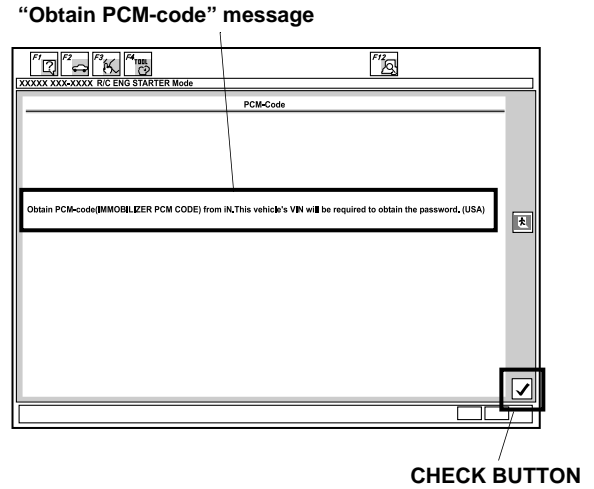

10. Input the PCM code, then click the check button.
NOTE: To ensure security, the PCM code (password) is changed every day, so it is impossible to register the remote engine starter if the date of the PCM code acquisition and registration are different. The date of the HDS tester should also be the same.

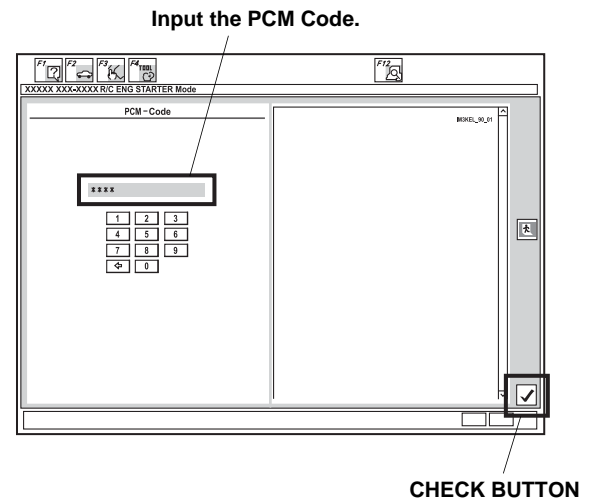

11. The following message will display: **The registration of the Remote Control Engine Starter Unit has been completed.** Click the check button.

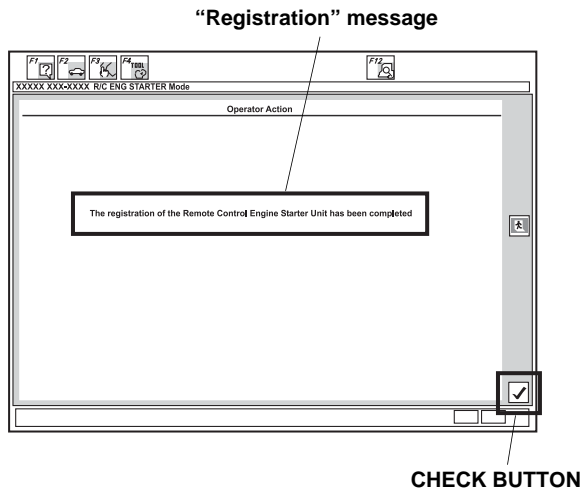

12. The following message will display: **Check that the engine can be started by the Transmitter.** Click the check button.

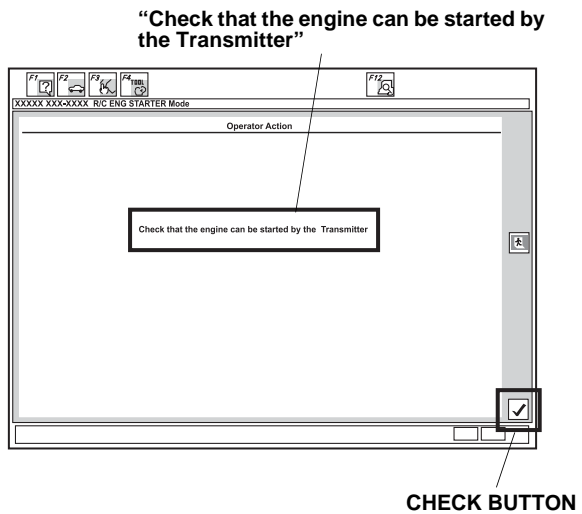

13. Perform the function test on page 20, then disconnect the HDS.

FUNCTION CHECK

Operating Conditions

- The hood is closed.
- The shift lever is in Park.
- The key is not in the ignition switch.
- All doors and tailgate are closed and locked.

Inspection

1. Press the command button, and then, within 1 second, press the start button on the transmitter. The engine should start if all operating conditions are met.

Does the engine start?

Yes - Operation is normal.

No:

- | |
|--|
| <ul style="list-style-type: none">• Make sure all operating conditions are met.• Check the engine starter harness connections.• Connect the HDS and check for an indicated failure. (Refer to the appropriate service manual for details.) |
|--|

2. Press the command button on the transmitter and, within 1 second, press the stop button. The engine should stop.

Does the engine stop?

Yes - Operation is normal.

No - Check the engine starter harness connections.
--

3. After the engine has stopped, start the engine again, and check that the engine stops after each of the following conditions:

NOTE: After each test, the ignition key must be cycled, or the driver's door must be opened and closed.

- Move the shift lever out of the P position.
- Unlock or open the doors or the tailgate.
- Open the hood.
- Insert the key in the ignition switch.
- Press on the brake pedal.

Does the engine stop after each of these tests?

Yes - Operation is normal.

No - Check the engine starter harness connections.
--

4. Check that the power windows do not function when the engine is started with the transmitter.
5. Press the command button on the transmitter twice and check the vehicle condition on the display.
6. Check the operation of the transmitter when the vehicle is 100 m to 150 m (325 to 490 ft.) away, with the vehicle in plain sight.

