

HONDA
INSTALLATION
INSTRUCTIONS

Accessory
BACK-UP SENSORS

Application
2009 PILOT

Publications No.
All 39418
 Issue Date
MAY 2008

PARTS LIST

Back-up Sensor Attachment Kit
P/N 08V67-SZA-100A

Back-up sensor harness

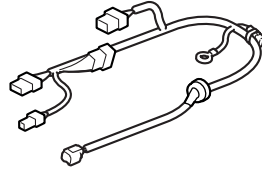

Back-up sensor subharness

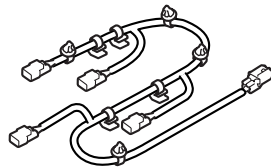

Control unit

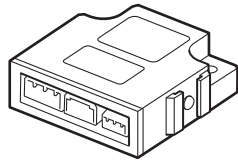

Control unit bracket



14 Wire ties

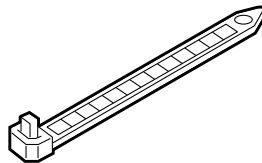

Harness tape



Clip



Fuse label



Cushion tape

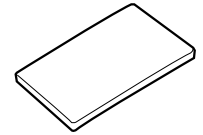

2 Flange nuts, 6 mm

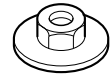

Switch

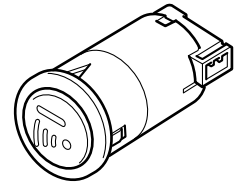

Switch bracket

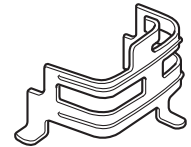

Small wire tie

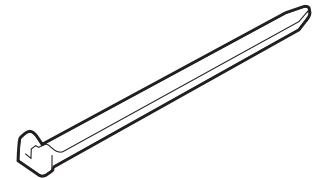

Offset wire tie

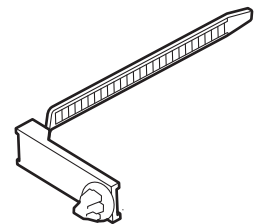

Coupler clip



Buzzer



4 Sensor clips

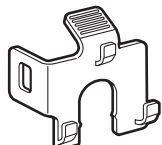

Buzzer bracket

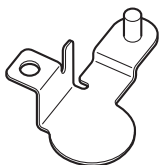

User's information

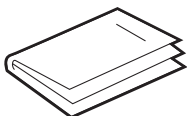

Back-up Sensor Kit

2 Corner sensors

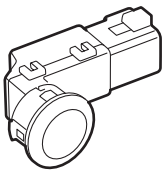

2 Center sensors (Larger)

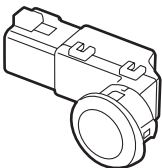

TOOLS AND SUPPLIES REQUIRED

- Phillips screwdriver
- Flat-tip screwdriver
- Small flat-tip screwdriver
- Shop towel
- Diagonal cutters
- Ratchet
- 8 mm, 10 mm, and 14 mm Sockets
- 10 mm Combination wrench
- Utility Knife
- T15 Torx Wrench
- Felt-tip pen
- Tape
- Pushpin
- Drill
- 3 mm Drill bit
- 24 mm and 26 mm Hole saws T/N AKS052507
- Isopropyl alcohol
- Plastic Trim Tool T/N SILTRIMTL10
- Eye protection
- Scissors
- Small rubber mallet

Illustration of the Back-up Sensors Installed on the Vehicle

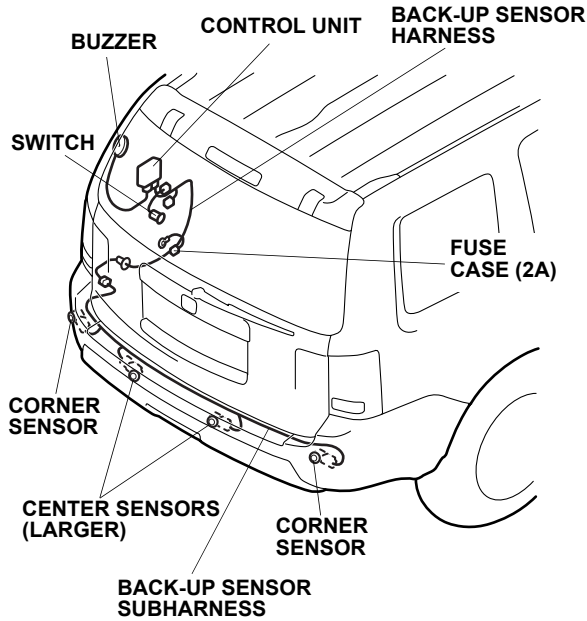

INSTALLATION

Customer Information: The information in this installation instruction is intended for use only by skilled technicians who have the proper tools, equipment, and training to correctly and safely add equipment to your vehicle. These procedures should not be attempted by “do-it-yourselfers.”

1. Make sure you have the anti-theft code for the audio unit and the navigation system, then write down the radio presets.
2. Disconnect the negative cable from the battery.

3. Remove the rear cargo tray (ten clips).

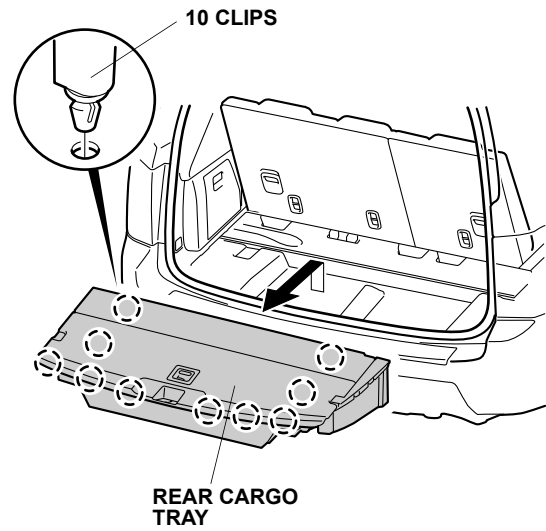

4. Use a plastic trim tool and, remove the cover (four retaining tabs).

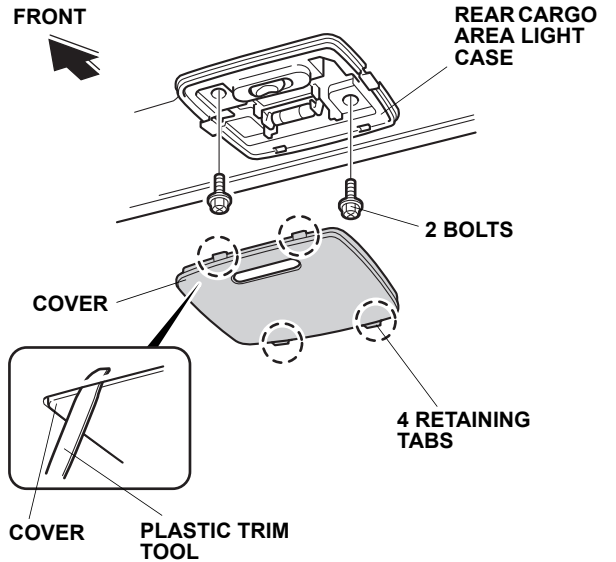

5. Remove the two bolts from the rear cargo area light case.

- Release the seat belt from the rear upper trim and remove the rear upper trim (four clips and unplug the vehicle connector).

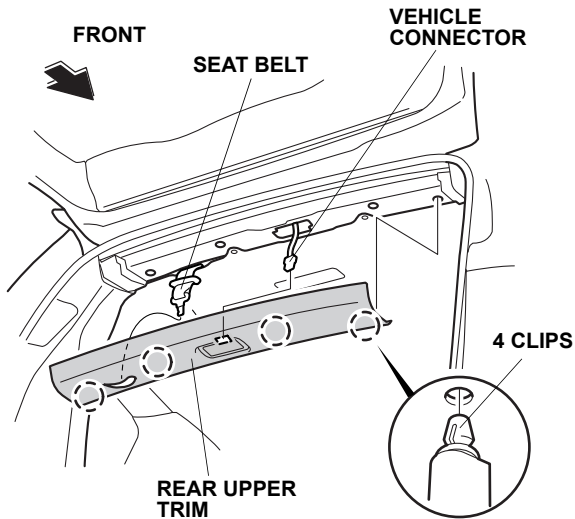

- Remove the two seat belt covers (four retaining tabs).

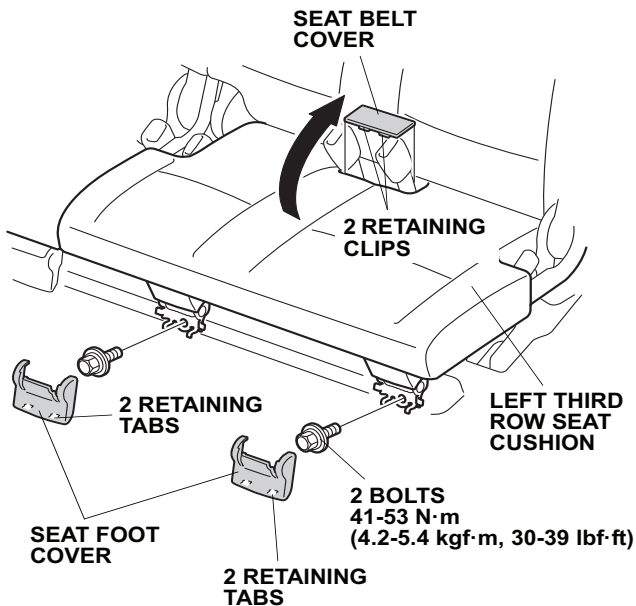

- Remove two bolts that fasten the left third row seat to the floor. Raise the left third row seat cushion.
- Remove the seat belt cover (two retaining clips).

- Using a small flat-tip screwdriver, push and release the seat belt lower hook from each third row seat. Insert the seat belt lower hook to the fix hole.

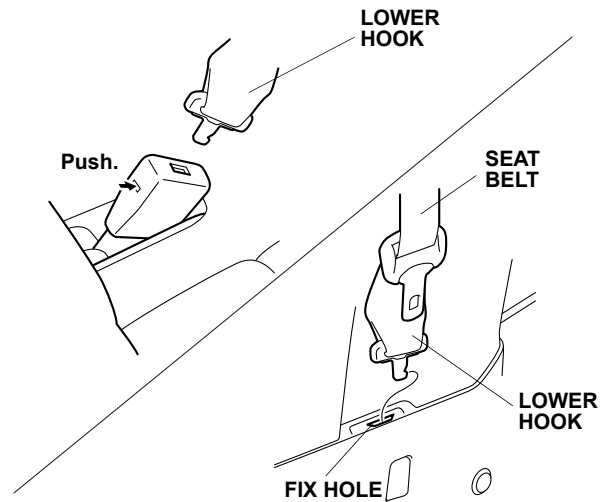

- Remove the two seat belts from the left third row seat and remove the four bolts fastening the left third row seat to the floor. Remove the left third row seat.

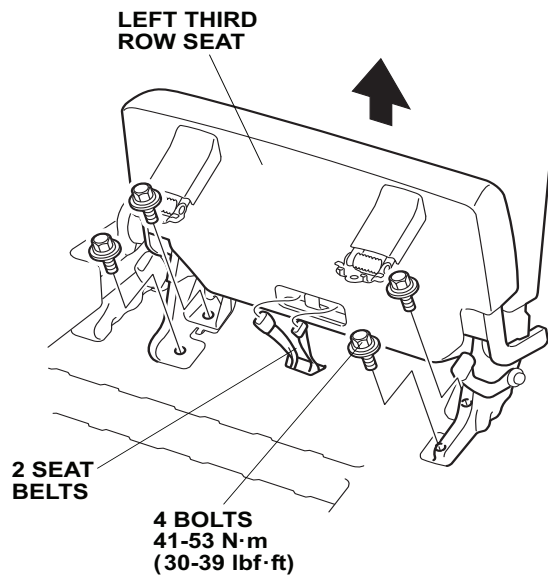

12. Release the left rear side sill trim (four clips).

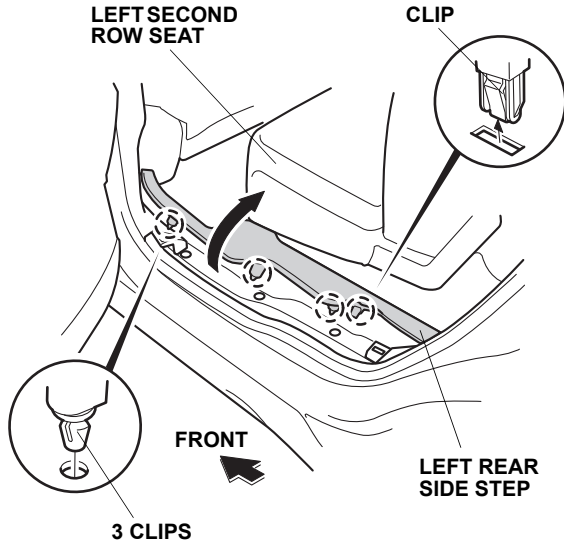

13. Open the two covers of the two tie-down hooks. Remove the two tie-down hooks from the left rear side liner (two screws).

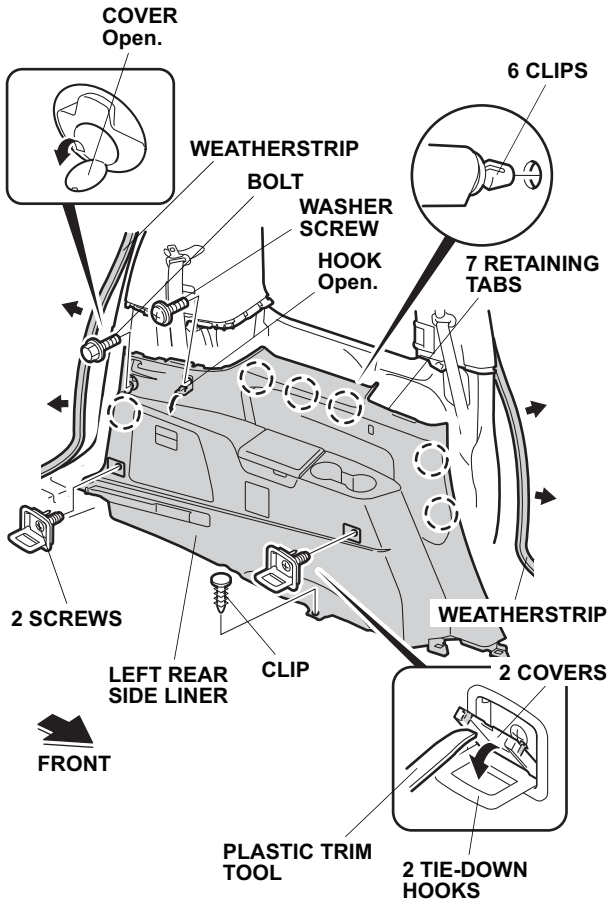

14. Remove the weatherstrips in the area shown. Remove the left rear side lining (one hook, one bolt,

one washer screw, one clip, six clips, and seven retaining tabs).

15. Using a plastic trim tool, open the lid of the left C-pillar trim (two retaining tabs).

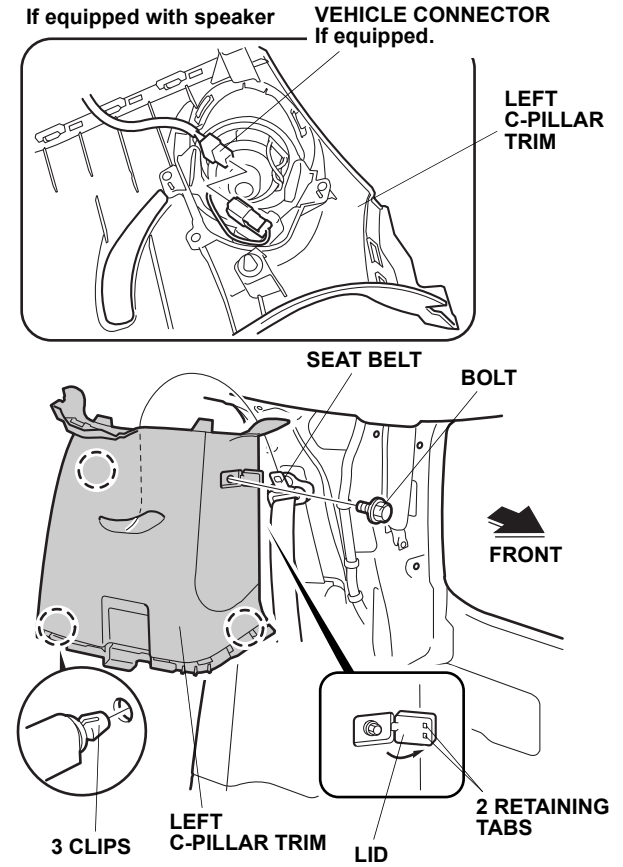

16. Using a small rubber mallet and a shop towel, gently tap the left C-pillar trim at the area marked "SIDE CURTAIN AIRBAG" to release the clip.

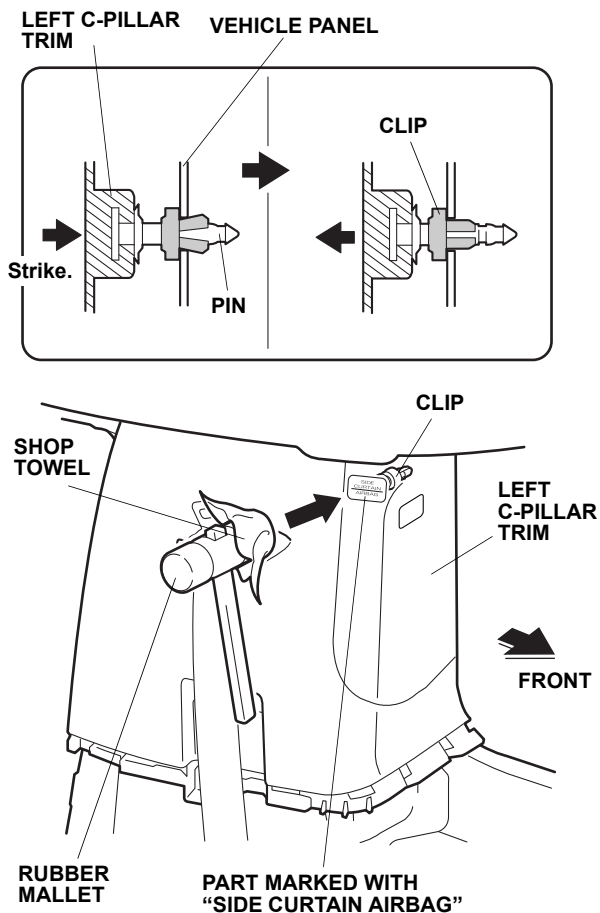

17. Remove the bolt from the left c-pillar trim.
 18. Release the seat belt from the left C-pillar trim and remove the left c-pillar trim (three clips and unplug the vehicle connector if equipped).
 19. Remove the clip from the left C-pillar trim, and install a new clip (supplied) to the left C-pillar trim.

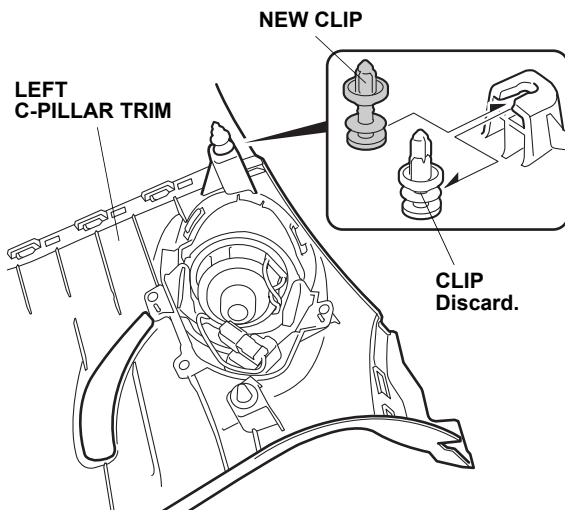

20. Remove the rear bumper (two clips, two bolts, two hex bolts and twelve self-tapping screws). Have an assistant help you when removing and installing the rear bumper.

NOTE: Push down on the top of the rear bumper while pulling the bumper out.

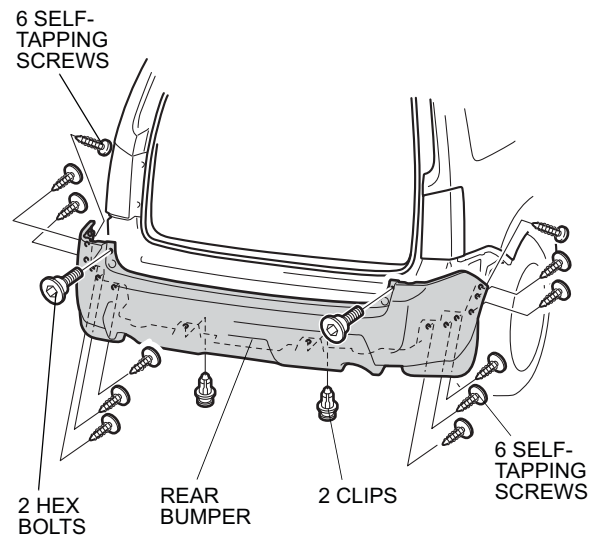

Installing the Control Unit

21. Install the control unit bracket on the control unit.

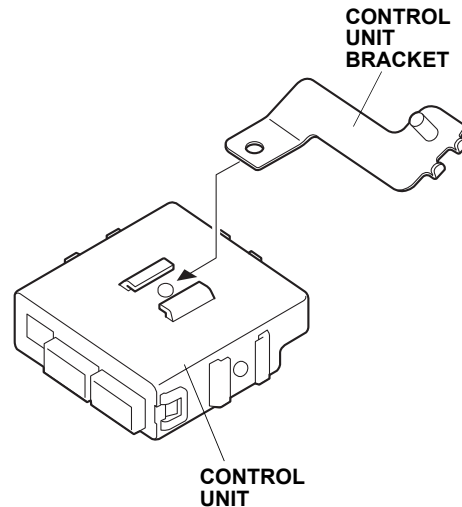

22. Secure the control unit bracket to the vehicle panel with the 6 mm flange nut.

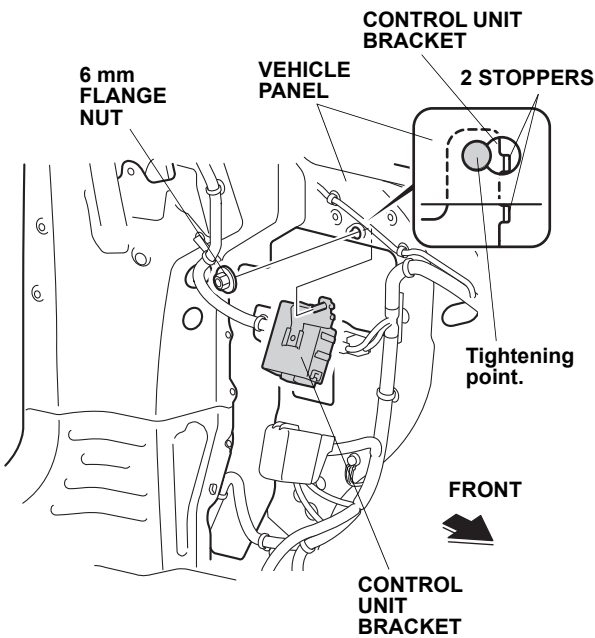

Installing the Buzzer

23. Release the vehicle harness clip from the vehicle panel, and cut the clip to remove it from the vehicle harness.

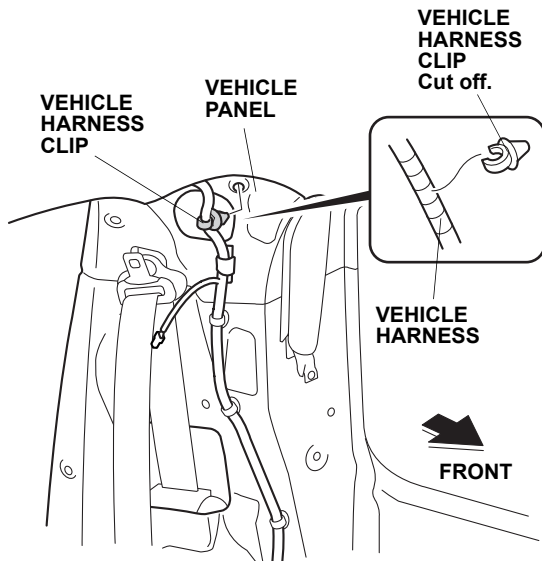

24. Using an isopropyl alcohol on a shop towel, clean the area where the buzzer will attach. Remove the adhesive backing from the buzzer, and attach the buzzer to the buzzer bracket as shown.

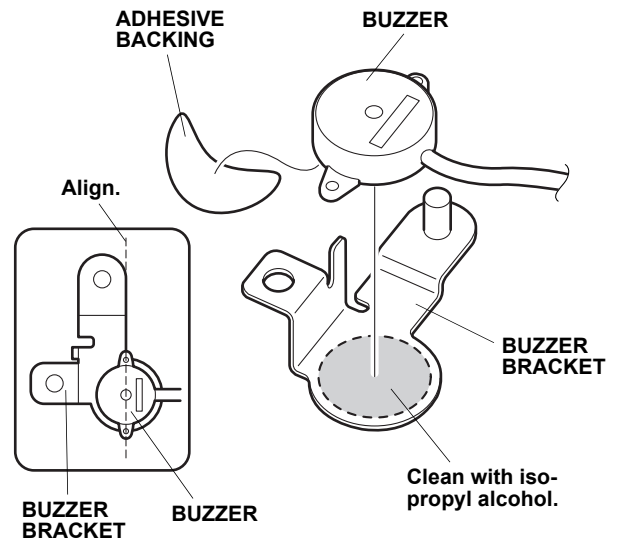

25. Using one 6 mm flange nut, secure the buzzer bracket to the vehicle panel in the position where the vehicle harness clip was removed in step 23.

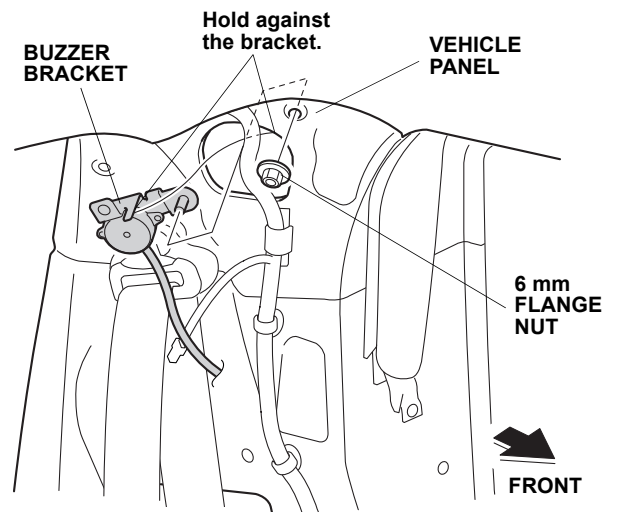

26. Secure the vehicle harness to the buzzer bracket with the offset wire tie as shown.

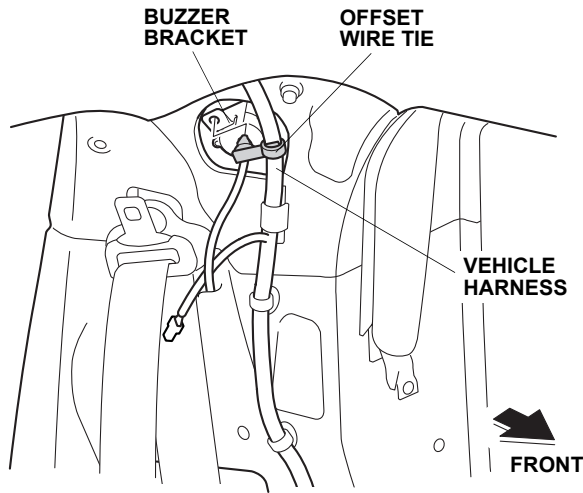

27. Route the buzzer harness along the vehicle harness, and secure it to the vehicle harness with two wire ties.

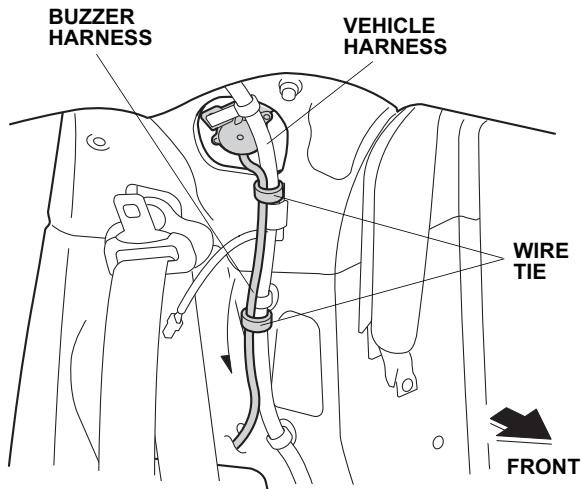

28. Secure the buzzer harness to the vehicle harness with three wire ties.

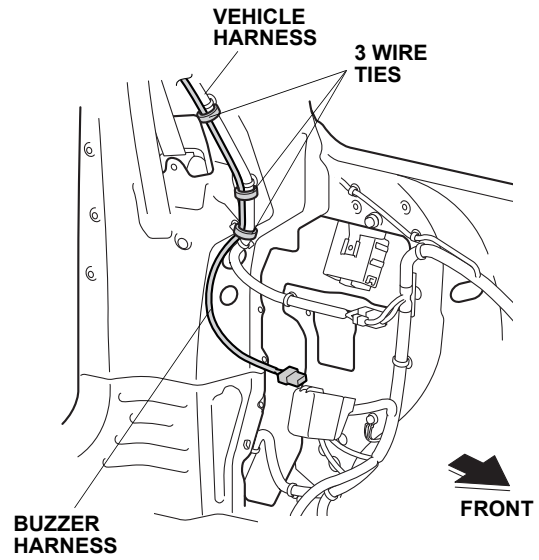

29. Plug the buzzer connector to the control unit. Bundle up the excess buzzer harness and loosely secure it to the vehicle harness with one wire tie.

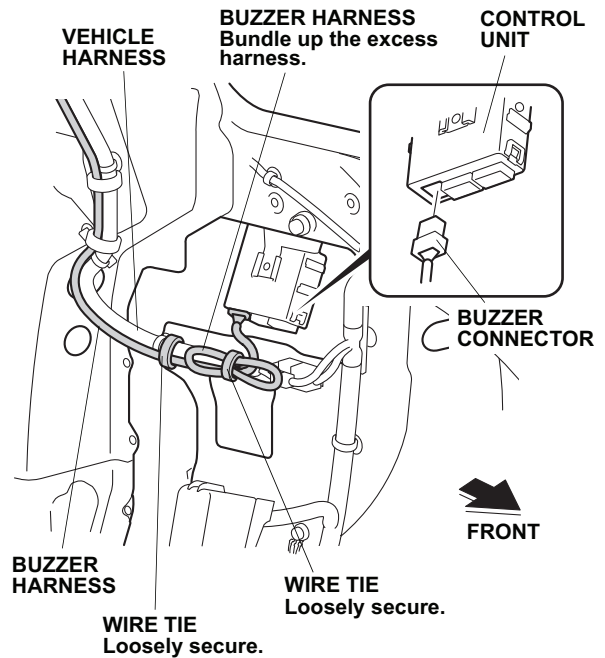

30. Loosely secure the buzzer harness to the vehicle harness with one wire tie.

Routing the Back-up Sensor Harness

31. Attach the 2A fuse label to the fuse case on the back-up sensor harness.

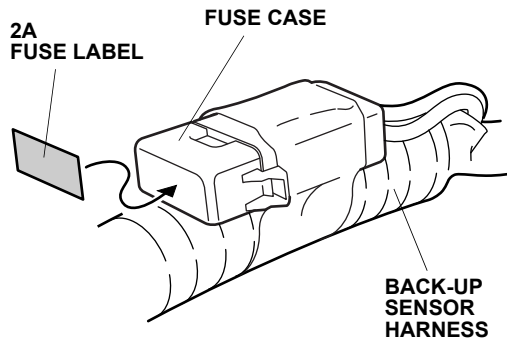

32. Plug the back-up sensor harness 12-pin connector to the control unit.

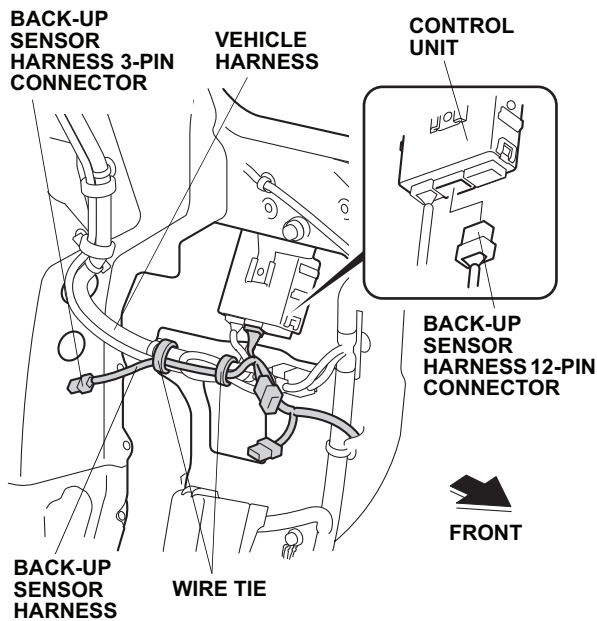

33. Route the back-up sensor harness 3-pin connector as shown and secure it to the vehicle harness with two wire ties loosely secured in step 29 and 30.

34. Unplug the vehicle 23-pin connector, and plug the back-up sensor harness 23-pin connector to the vehicle 23-pin connector as shown.

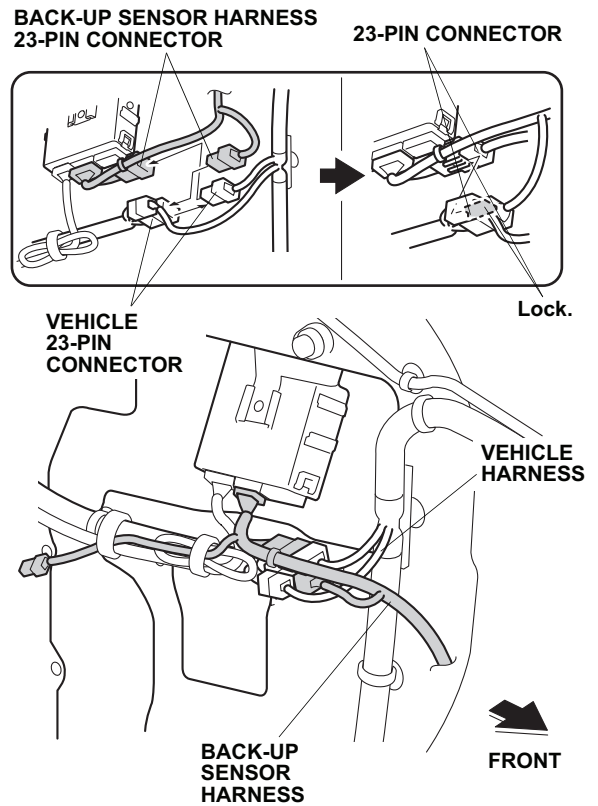

35. Lock the 23-pin connectors as shown.

36. Route the back-up sensor harness on the underside of the vehicle, and secure it to the vehicle harness with three wire ties.

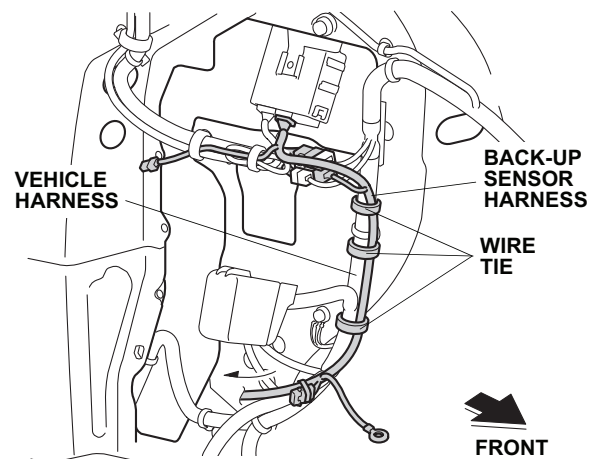

37. Remove the vehicle ground bolt from the vehicle ground terminal. Secure the back-up sensor harness ground terminal to the vehicle ground terminal with the vehicle ground bolt you just removed.

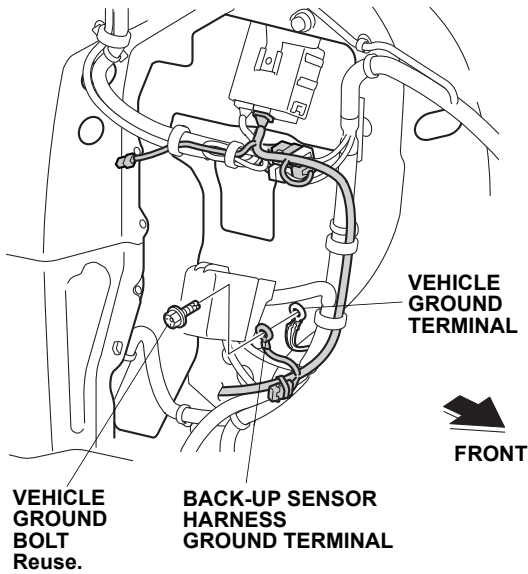

38. Route the back-up sensor harness on the rear side of the vehicle, and secure it to the vehicle harness with three wire ties.

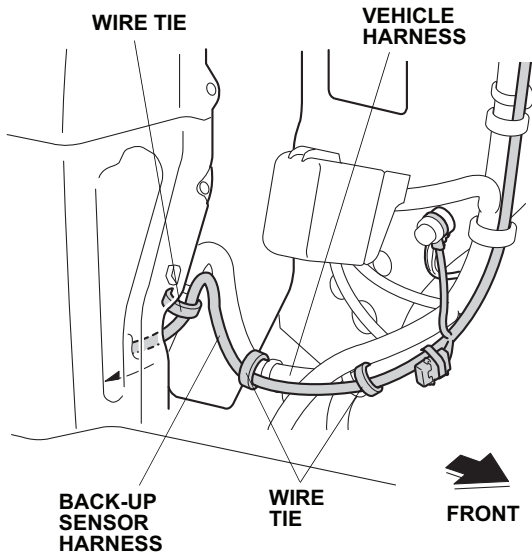

39. Remove the vehicle grommet from the vehicle panel.

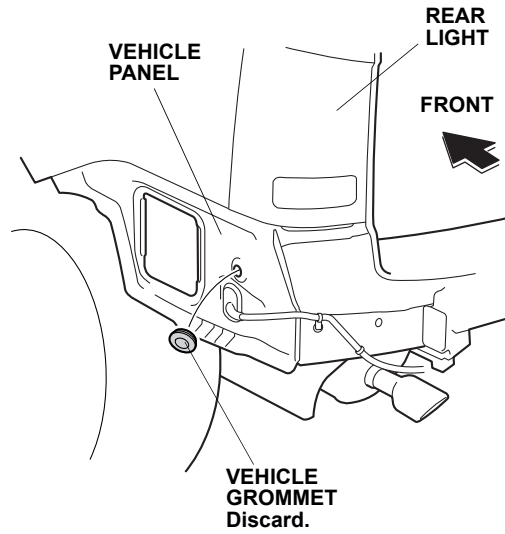

40. Route the back-up sensor harness through the vehicle grommet hole, and install the back-up sensor harness grommet onto the vehicle panel.

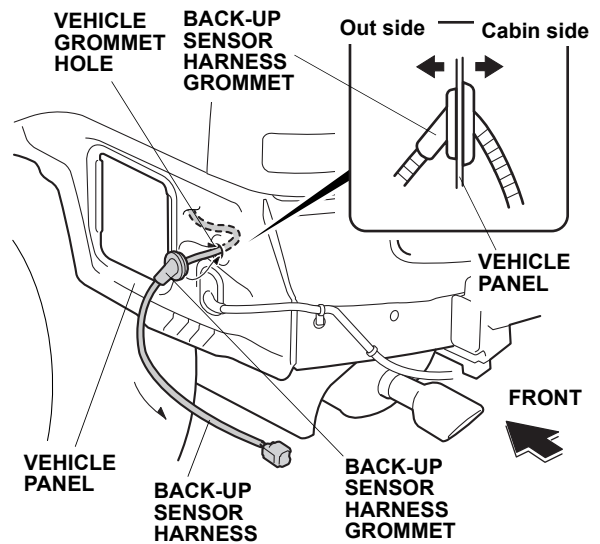

- Slide the coupler clip onto the back-up sensor harness 6-pin connector, and secure it to the vehicle panel.

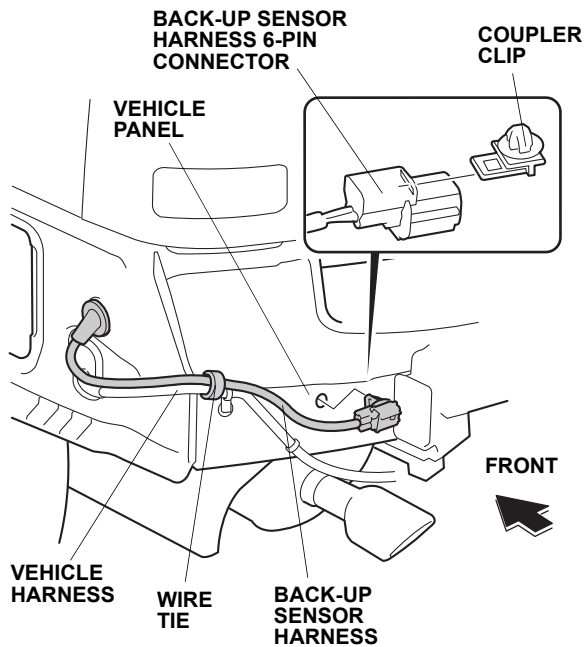

- Secure the back-up sensor harness to the vehicle harness with one wire tie.

Installing the Switch

- On the back of the left rear side liner, cut the insulator to the measurement as shown.

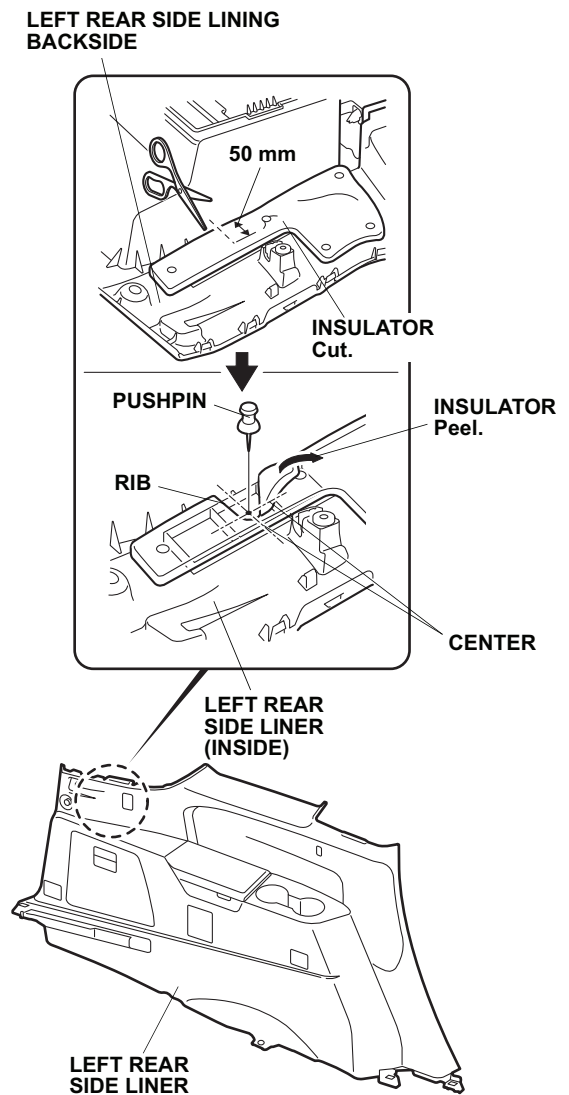

- Using a pushpin, mark the left rear side liner in the center of the square as shown.

45. While wearing eye protection, drill at the mark made in step 44 using a 26 mm hole saw. Remove any burrs.

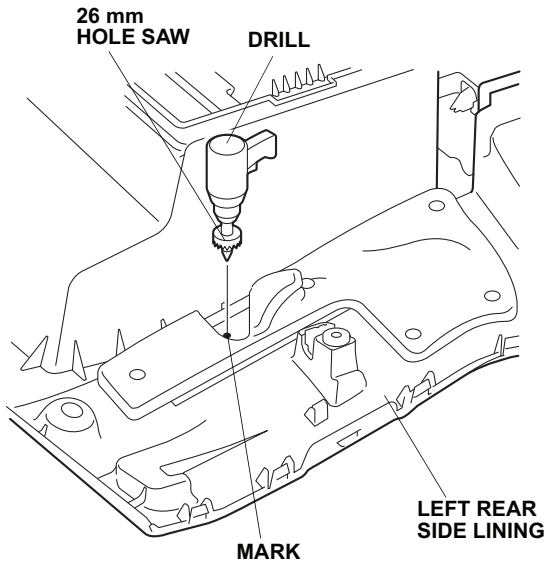

46. Using a scissors, cut the cushion tape to the dimension shown.

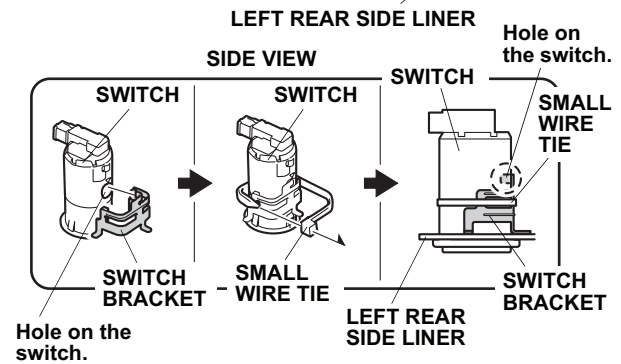
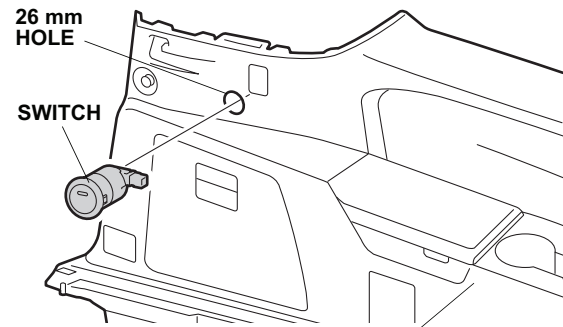
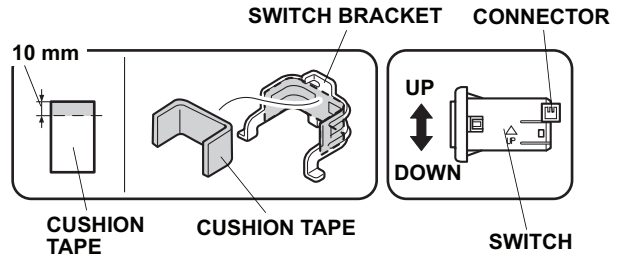

47. Using an isopropyl alcohol on a shop towel, clean the area where the cushion tape will attach. Attach the cut cushion tape you cut in step 46 to the switch bracket as shown.
48. Insert the switch into the 26 mm hole, and install the switch bracket onto the switch as shown.
49. Secure the switch bracket to the switch with one small wire tie.

50. Plug the back-up sensor harness 3-pin connector to the switch. Reinstall the left rear side lining and C-pillar trim.

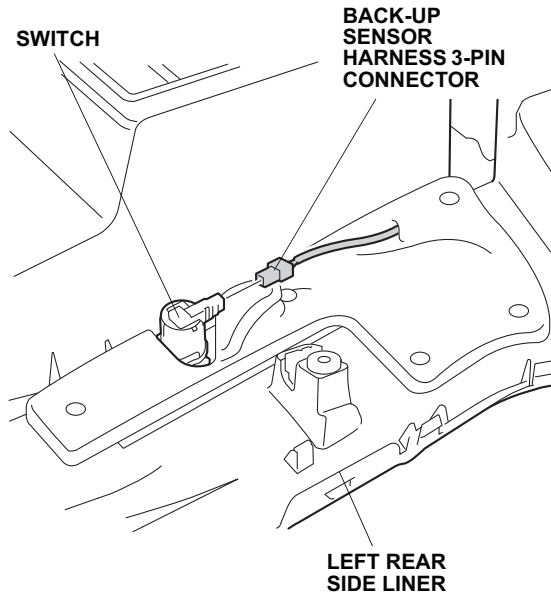

Installing the Back-up Sensor

51. Locate the four preset marks on the inside of the bumper. Using a pushpin, pierce each of the four preset marks in two places. Make sure you pierce the right center mark in the center and the bottom.

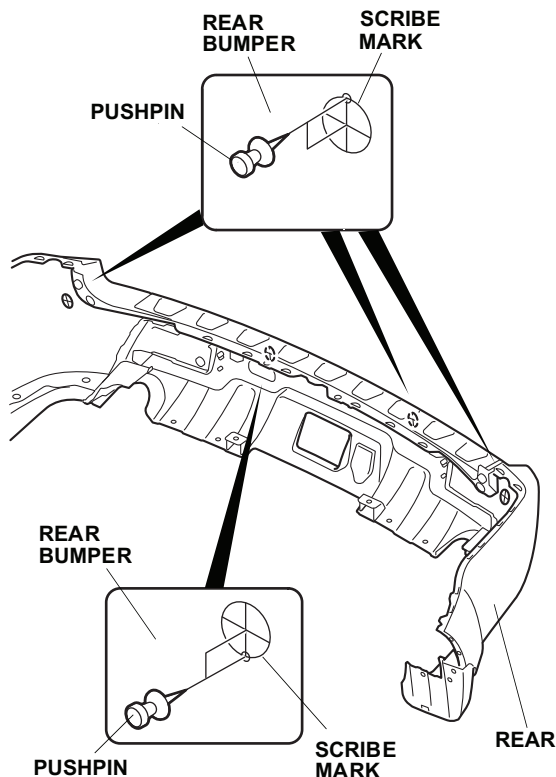

52. While wearing eye protection, drill at the upper out board pierced marks with a 3 mm bit. Drill the two outboard center marks using a 24 mm hole saw. Remove all burrs.

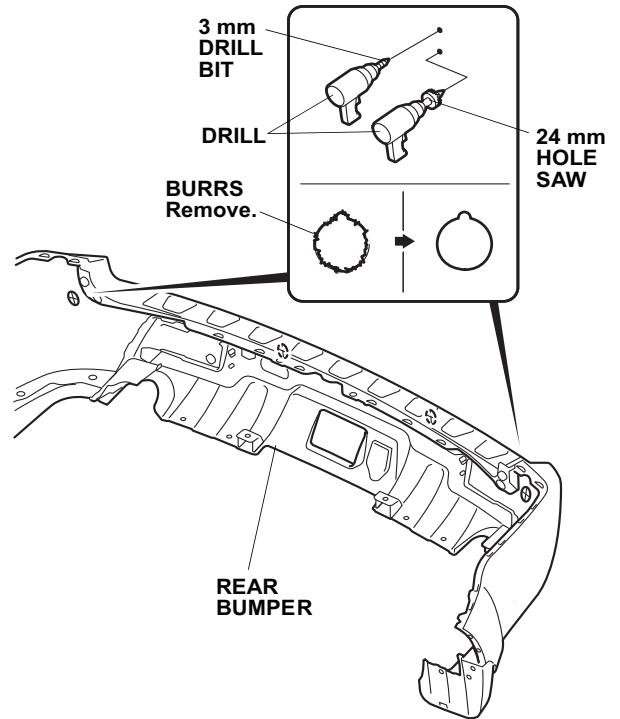

53. While wearing eye protection drill the *right center mark* at the *upper* pierced mark with a 3 mm drill bit. On the *left center mark*, drill the *lower* pierced mark with a 3 mm drill bit. Then drill the two center marks using a 26 mm hole saw. Remove all burrs.

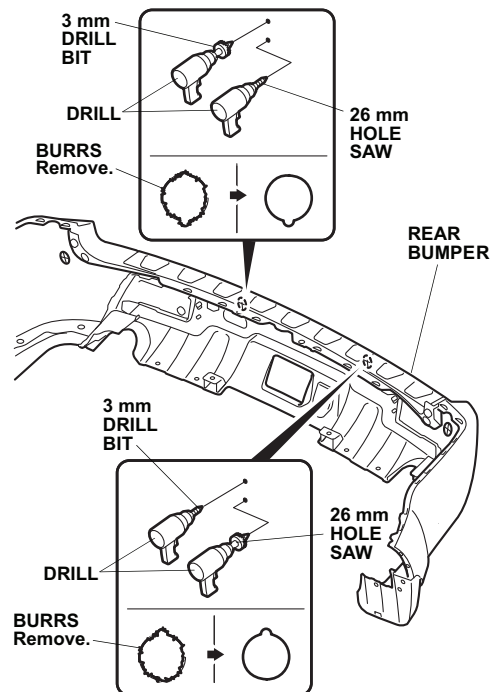

54. Install the two corner sensors on the rear bumper using one sensor clip for each sensor.

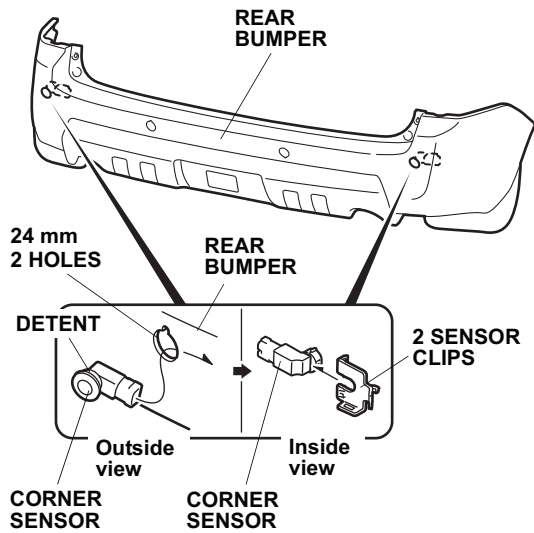

55. Install the two center sensors on the rear bumper using one sensor clip for each sensor.

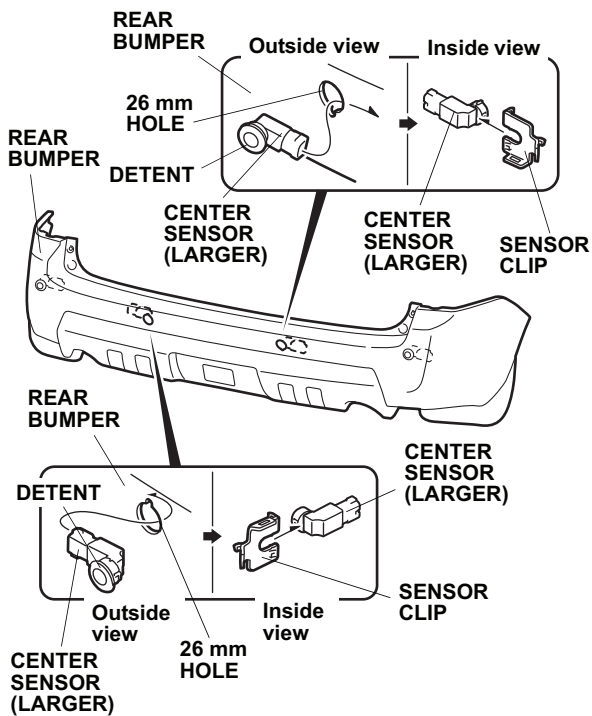

56. Plug the four back-up sensor subharness 2-pin connectors to the two corner sensors and two center sensors.

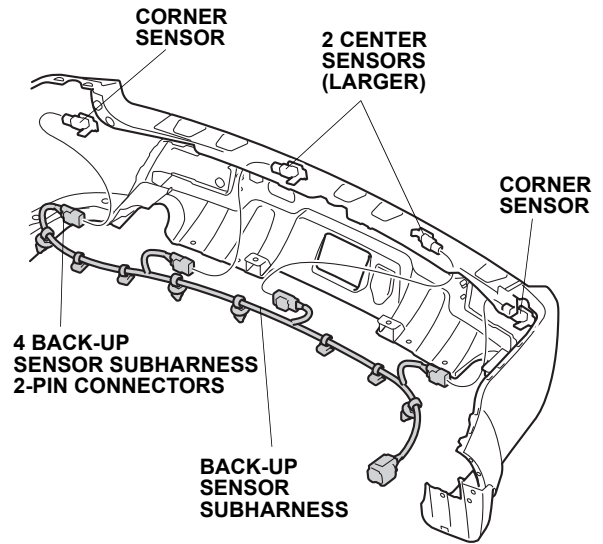

57. Attach three back-up sensor subharness clips (A) into three sensor clips.

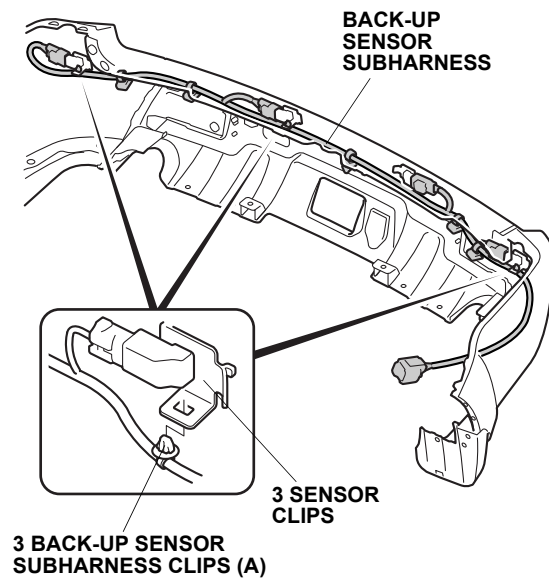

62. Check that all wire harnesses are routed properly and all connectors are plugged in.
63. Reinstall all removed parts.
64. Reconnect the negative cable to the battery.
65. Enter the customer's audio system or navigation system anti-theft code.
66. Reset the clock.
67. Check the back-up sensors function as described in the Accessory back-up sensor User's Information Manual.
68. Put the User's Information Manual in the glove box.